



**THE  
PREVENTIVE  
MAINTENANCE  
MONTHLY**

**ISSUE 783 FEBRUARY 2018**

**The Night Knight**

**27-34**



**SMALL ARMS**

**35**

M16-Series Rifle, M4/M4A1 Carbine Action Spring Length	36
M2A1 Machine Gun Trigger Lever Stop Assembly	37
Sniper Rifle Advanced Ballistic Weather Meter NSN	37
M16-Series Rifle, M4/M4A1 Carbine Magazine PM	38-40
M240B Machine Gun Heat Shield Replacement Criteria	40



**COMBAT VEHICLES**

**2**

M1-Series Tank, Weekly Starts Prevent Battery Drain	3
M1-Series Tank, Turret Basket Screens Reminder	4-5
M1A1 SEP Tank, Proper Hub Cap Installation	6
Stryker, Hub Fill Plug O-Ring Prevents Leaks	7
M1134 ATGM Stryker, Hands off Hatch Override Switch	8
M113-Series FOV, Ramp Pulley Housing Protection	9



**TACTICAL VEHICLES**

**10**

Rust Busters Tip of the Month	11-13
FMTV, 100-Amp Alternator Replaced	14
PLS CROP Flatrack Ratchet Strap Replaced	15
M915A5 Tractor Truck Oil Change Interval Increased	15



**CONSTRUCTION**

**16**

966H Wheel Loader Bucket Lubing	17
M1231 MK III VMMD Husky Transmission Filter Access Cover Locking Pins Danger	18
6K, ATLAS Forklift Axle Lubing Tips	19



**AVIATION**

**20**

AH-64D/E, New Helmet TM Available	21
IHADSS, AIHS Helmet Bag Protection	22-23
UH-72A Lakota FAQ on JTDI Website	23
CH-47 Series Rotor Blade Adjustment Tool	24-25
AH-64 Support Actuator Assembly Turn-in	25
UH-60 Series ERF5 Tank Turn-in	26
Primary Survival Gear Carrier Zipper Repair	26



**CBRN**

**41**

M26, M12A1 Decon Cold Weather Prep	41
------------------------------------	----



**TOOLS**

**42**

Caps, Plugs and Bags NSNs	42-43
Industrial Gas Program	44-45
Vehicle Support Stand Q&A	46-48



**COMMUNICATIONS**

**49**

DISE Replaced by PDISE	50-51
15-kW AMMPS Generator Oil Filter NSN	51



**SOLDIER SUPPORT**

**52**

DD Form 1380 Provides Critical Emergency Care Info	52
--	----



**LOGISTICS MANAGEMENT**

**53**

HMIRS Next Gen Intro	54-55
DA Form 348, Keep for Out-processing/Retirement	55
Operators TM Stays with Equipment	56-58
DLA Office Device Management Program	59

**Connie's Post Scripts**

**60-61**

TB 43-PS-783, *The Preventive Maintenance Monthly*, is an official publication of the Department of the Army, providing information for all Soldiers assigned to combat and combat support units and all Soldiers with unit maintenance and supply duties. All information published has been reviewed and approved by the authority responsible for the equipment, publication or policy discussed. Application of the information is optional with the user. Masculine pronouns may refer to both genders. The use of product or company names does not constitute endorsement of those products, services or companies by the U.S. Army. The use of non-DoD hyperlinks, along with their content, does not constitute endorsement by DoD or DA. Neither DoD nor DA exercises any editorial control over, and cannot vouch for, content on non-DoD websites.

**PS, The Preventive Maintenance Monthly (ISSN 0475-2953)**

is published monthly by the Department of the Army, Redstone Arsenal, AL 35898.

You are invited to send PS your ideas for improving maintenance procedures, questions on maintenance and supply problems and questions or comments on material published in PS.

Just write to:

**MSG Half-Mast**

**PS, the Preventive Maintenance Monthly**

**USAMC LOGSA (AMXLS-GP)**

**Bldg. 3303**

**Redstone Arsenal, AL 35898**

Or email:

**usarmy.redstone.logsa.mbx.psmag@mail.mil**

Internet address:

**https://www.logsa.army.mil/psmag/pshome.cfm**

By order of the Secretary of the Army:

**MARK A. MILLEY**

General, United States Army Chief of Staff

Official:

**GERALD B. O'KEEFE**

Administrative Assistant to the Secretary of the Army

1732562

Issue 783

# PS

★  
February  
2018

## THE PREVENTIVE MAINTENANCE MONTHLY

TB 43-PS-783

Approved for  
Public Release;  
Distribution is  
Unlimited

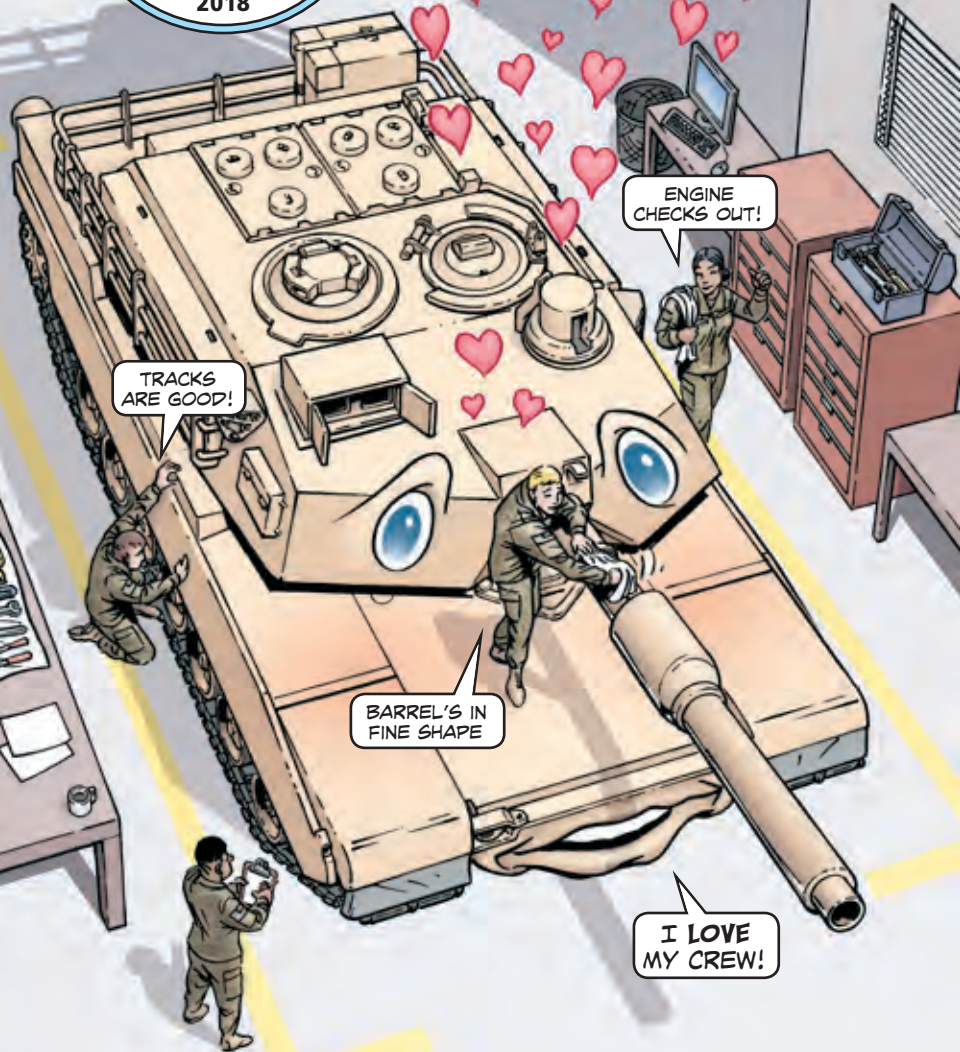

TRACKS  
ARE GOOD!

ENGINE  
CHECKS OUT!

BARREL'S IN  
FINE SHAPE

I LOVE  
MY CREW!



**THE  
PREVENTIVE  
MAINTENANCE  
MONTHLY**

**ISSUE 783 FEBRUARY 2018**



**COMBAT VEHICLES 2**

- M1-Series Tank, Weekly Starts Prevent Battery Drain 3
- M1-Series Tank, Turret Basket Screens Reminder 4-5
- M1A1 SEP Tank, Proper Hub Cap Installation 6
- Stryker, Hub Fill Plug O-Ring Prevents Leaks 7
- M1134 ATGM Stryker, Hands off Hatch Override Switch 8
- M113-Series FOV, Ramp Pulley Housing Protection 9



**TACTICAL VEHICLES 10**

- Rust Busters Tip of the Month 11-13
- FMTV, 100-Amp Alternator Replaced 14
- PLS CROP Flatrack Ratchet Strap Replaced 15
- M915A5 Tractor Truck Oil Change Interval Increased 15



**CONSTRUCTION 16**

- 966H Wheel Loader Bucket Lubing 17
- M1231 MK III VMMD Husky Transmission Filter Access Cover Locking Pins Danger 18
- 6K, ATLAS Forklift Axle Lubing Tips 19



**AVIATION 20**

- AH-64D/E, New Helmet TM Available 21
- IHADSS, AIHS Helmet Bag Protection 22-23
- UH-72A Lakota FAQ on JTDI Website 23
- CH-47 Series Rotor Blade Adjustment Tool 24-25
- AH-64 Support Actuator Assembly Turn-in 25
- UH-60 Series ERF5 Tank Turn-in 26
- Primary Survival Gear Carrier Zipper Repair 26

**The Night Knight 27-34**



**SMALL ARMS 35**

- M16-Series Rifle, M4/M4A1 Carbine Action Spring Length 36
- M2A1 Machine Gun Trigger Lever Stop Assembly 37
- Sniper Rifle Advanced Ballistic Weather Meter NSN 37
- M16-Series Rifle, M4/M4A1 Carbine Magazine PM 38-40
- M240B Machine Gun Heat Shield Replacement Criteria 40



**CBRN 41**

- M26, M12A1 Decon Cold Weather Prep 41



**TOOLS 42**

- Caps, Plugs and Bags NSNs 42-43
- Industrial Gas Program 44-45
- Vehicle Support Stand Q&A 46-48



**COMMUNICATIONS 49**

- DISE Replaced by PDISE 50-51
- 15-kW AMMP5 Generator Oil Filter NSN 51



**SOLDIER SUPPORT 52**

- DD Form 1380 Provides Critical Emergency Care Info 52



**LOGISTICS MANAGEMENT 53**

- HMIRS Next Gen Intro 54-55
- DA Form 348, Keep for Out-processing/Retirement 55
- Operators TM Stays with Equipment 56-58
- DLA Office Device Management Program 59

**Connie's Post Scripts 60-61**

TB 43-PS-783, The Preventive Maintenance Monthly, is an official publication of the Department of the Army, providing information for all Soldiers assigned to combat and combat support units and all Soldiers with unit maintenance and supply duties. All information published has been reviewed and approved by the agency responsible for the equipment, publication or policy discussed. Application of the information is optional with the user. Masculine pronouns may refer to both genders. The use of product or company names does not constitute endorsement of those products, services or companies by the U.S. Army. The use of non-DoD hyperlinks, along with their content, does not constitute endorsement by DoD or DA. Neither DoD nor DA exercises any editorial control over, and cannot vouch for, content on non-DoD websites.

**PS, The Preventive Maintenance Monthly** (ISSN 0475-2953) is published monthly by the Department of the Army, Redstone Arsenal, AL 35898.

You are invited to send PS your ideas for improving maintenance procedures, questions on maintenance and supply problems and questions or comments on material published in PS.

Just write to:  
MSG Half-Mast  
PS, the Preventive Maintenance Monthly  
USAMC LOGSA (AMXLS-GP)  
Bldg. 3303  
Redstone Arsenal, AL 35898

Or email:  
usarmy.redstone.logsa.mbx.psmag@mail.mil

Internet address:  
https://www.logsa.army.mil/psmag/pshome.cfm

By order of the Secretary of the Army:  
**MARK A. MILLEY**  
General, United States Army Chief of Staff

Official:  
  
**GERALD B. O'KEEFE**  
Administrative Assistant to the Secretary of the Army

1732562

# Sew Up Your PM



THERE'S AN OLD SAYING THAT GOES "A STITCH IN TIME SAVES NINE."

WHOEVER FIRST SAID THAT IS A PERSON WHO UNDERSTOOD PREVENTIVE MAINTENANCE.

A little PM now saves you a lot of problems later. Cleaning out the carbon from the barrel of your rifle and lubing it properly might take a little extra time now, but what happens if it doesn't fire when you need it? You saved a few minutes on PM but now your life is in jeopardy.

Ever had a car break down on the side of the road and waited hours for a tow truck? If you thought that was unpleasant, try waiting for a tow in the middle of the desert, all because you decided to cut corners and didn't check the fluid levels in your HMMWV.

And if you take shortcuts with aircraft maintenance... well, let's not go there!





# COMBAT VEHICLES

- Regular Starts Prevent Battery Drain!
- Tighten Down Turret Basket Screens
- Install Hub Caps the Right Way!
- Don't Overlook O-Ring
- Override Runs Over Sight Door
- Watch Step to Stamp Out Ramp Damage



M1-Series Tanks...

# REGULAR STARTS PREVENT BATTERY DRAIN!

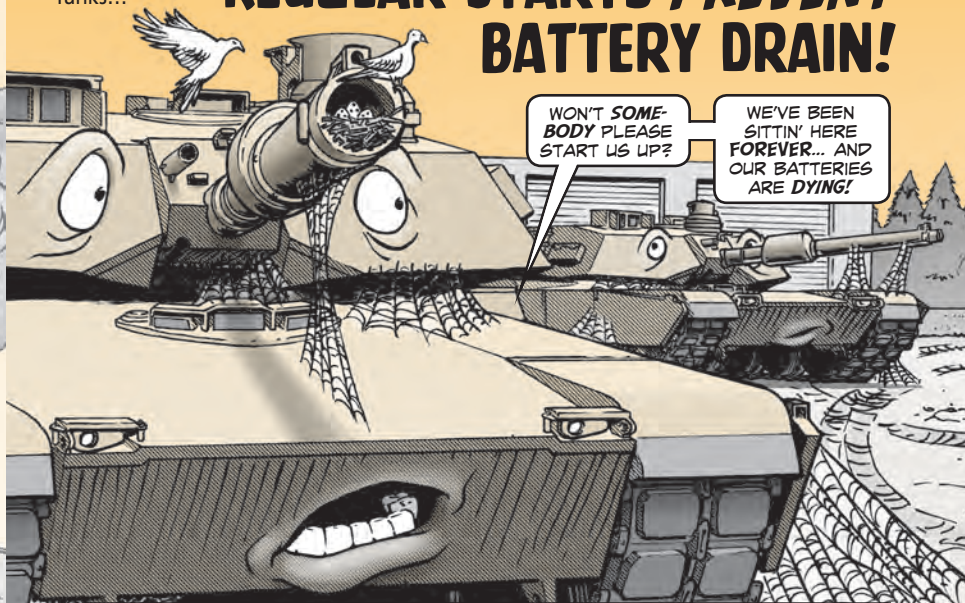

Dear Editor,

You'd be surprised at how many M1-series tanks sitting around the motor pool end up with dead batteries simply because crews don't start the engines on a regular basis.

Starting the engine is part of BEFORE PMCS, but it's a good idea to do it every week if possible. A lot of battery problems could be avoided if crews would just crank up those engines regularly.

Let the engine run for at least 30 minutes at tactical idle. That's because it takes the charging system 15 minutes to bring the battery charge level back to what it was before starting the engine.

Be sure to follow the engine start procedures in the -10 TMs to the letter. That prevents damage to electrical components like the FBCB2, reduces battery problems and increases unit readiness.

SSG Mike McCord  
Ft Bliss, TX

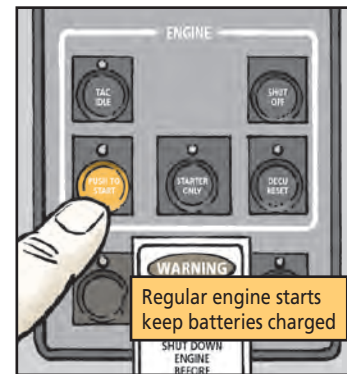

**Editor's note:** Crews, be sure to crank up battery PM with this charged-up tip!

# TIGHTEN DOWN TURRET BASKET SCREENS

LET'S GET SOME TRAINING DONE TODAY!

SOUNDS GOOD TO ME!

JUST MAKE SURE YOU SECURE MY TURRET BASKET SCREENS FIRST!

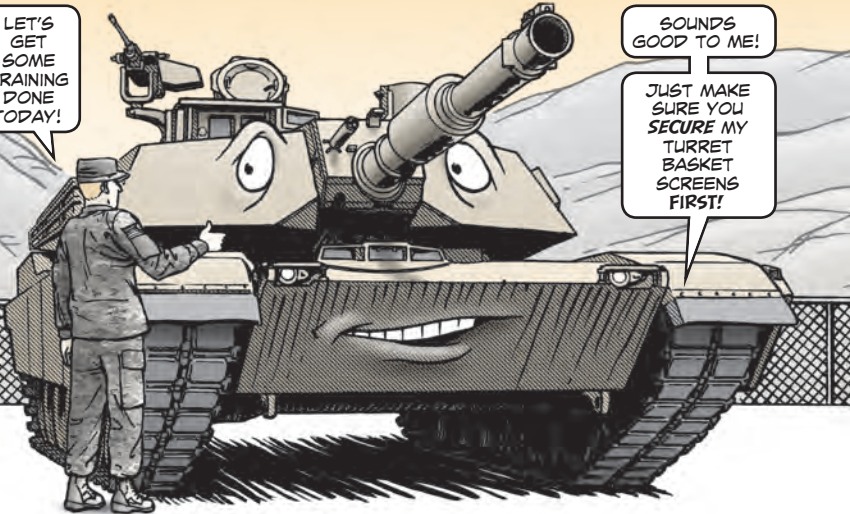

THAT'S A GOOD REMINDER, CHIEF.

CREWS, EACH SCREEN IS HELD IN PLACE WITH A SCREW, NSN 5305-01-388-5093, AND BALL STUD, NSN 5307-01-100-8166.



VIBRATION LOOSENS THE SCREW UNTIL IT FALLS OUT OR WORKS THE BALL STUD LOOSE FROM THE FRICTION RECEPTACLE ON THE BACK OF THE TURRET WALL BRACKET.

EITHER WAY, THE TOP OF THE SCREEN SAGS OUTWARD AND THE NEXT TIME THE TURRET IS TRAVERSED, THE SCREEN SNAGS AND RIPS CABLES AND CONNECTORS.

YOU CAN STOP LOOSE SCREWS BY APPLYING A LITTLE SEALING COMPOUND, NSN 8030-00-081-2339, TO THE THREADS BEFORE YOU TIGHTEN THEM. ALSO, PUT A FLAT WASHER, NSN 5310-01-389-9681, BETWEEN THE SCREW AND THE SCREEN.



Sealing compound keeps screws tight

Dear Editor,

Vehicles on maneuvers here at the National Training Center (NTC) take a beating from the rough desert terrain. That's why it's important for M1-series tank crews to make sure their turret basket screens inside the turret are tightened down before hitting the trail.

A lot of times, crews forget to put the screens back in place properly after PMCS. Then on the range, vibration causes the screens to pop loose. That results in cut cables and ripped-out connectors when the turret traverses. Then the tank is out of play until the damage is repaired.

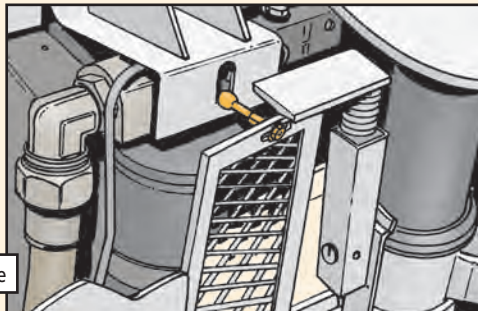

Vibration makes ball stud slip loose

It only takes a few seconds to make sure the screens are securely tightened down. Those few seconds can save you a ton of trouble and your unit a lot of money.

CW4 William Baker  
Ft Irwin, CA

IF THE BALL STUD COMES LOOSE IN ITS RECEPTACLE, USE PLIERS TO PINCH THE TWO TABS ON THE FRICTION RECEPTACLE BACK TOGETHER. THAT PROVIDES ENOUGH TENSION TO HOLD THE BALL STUD IN PLACE.



IF ONE OF THE TABS BREAKS OFF, REPLACE THE FRICTION RECEPTACLE WITH NSN 5340-01-100-8138.

YOUR TUH-TURRET BUH-BASKET SCREENS AR-ARE NICE AND SECURE.

JUH-JUST HOW I LUH-LIKE 'EM!



M1-Series Tank...

# INSTALL HUB CAPS THE RIGHT WAY!

I'M GONNA INSTALL YER NEW HUB CAP ALL BY MYSELF!

SHOULDN'T YOU LET A MECHANIC DO THAT?

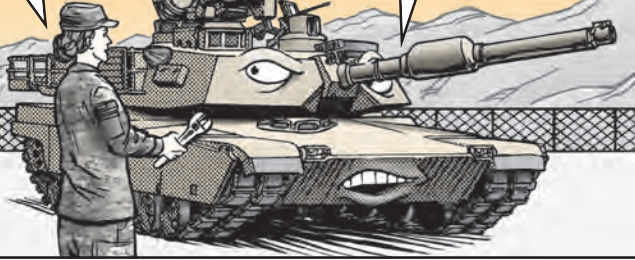

Dear Editor,

Leaky hub caps on the M1-series tank's roadwheels can lead to the hub bearings seizing up. That's an expensive repair. Even worse, combat readiness is reduced.

Units sometimes have crewmembers install the hub caps, NSN 2530-01-552-1192. Some crewmembers, lacking the proper training, have installed hub caps using the wrong tools and don't get the torque right. That's why replacing hub caps is best left to mechanics.

Mechanics should use torque wrench, NSN 5120-01-121-4981, to tighten the hub caps to 50-60 Ft/lb. They'll need to replace the O-ring, NSN 5331-01-067-3446, and Filler plug, NSN 5340-01-128-9554, when installing a new hub cap.

Improperly installed hub cap leads to leaks

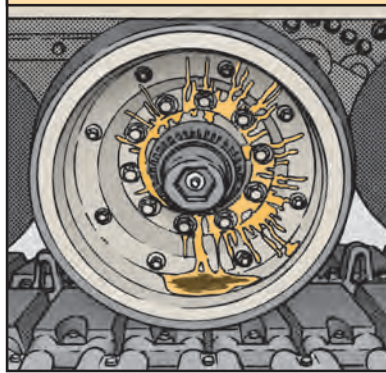

Replace O-ring, NSN 5331-01-067-3446...

...hub cap, NSN 2530-01-552-1192...

...and filler plug, NSN 5340-01-128-9554, at same time

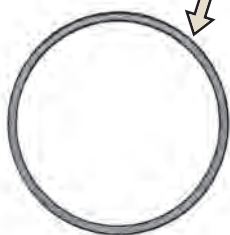

The full procedure for replacing hubcaps is found in TM 9-2350-264-23-1-1 (Jul 11, w/Ch 3, Mar 15) for the M1A1 and in TM 9-2350-388-13 in IETM EM 0334 (Aug 16) for the M1A2.

CW3 Lamar Smalls  
Ft Bliss, TX

**Editor's note:** This info will help units tighten up their hub cap maintenance!

Stryker...

LET'S ROLL, BUDDY!

I'M NOT ROLLING ANYWHERE CAUSE ONE OF MY WHEEL HUBS HAS SEIZED UP!

UGH!!



# Don't Overlook O-Ring

Dear Editor,

Sometimes crewmembers forget to reinstall the O-rings after they've added oil to their Stryker's wheel drive. Then the hub ends up with a Class III leak. Worst case scenario, the hub goes dry and the bearings burn up.

Whenever you pull the fill plug on the wheel drive, make sure you don't misplace the O-ring. If you do lose one, or find one that's damaged, replace it with NSN 5330-12-156-4524.

If the old O-ring is undamaged, wipe it off before reinstalling the plug. If there's a lot of dirt or sand on the O-ring, it won't seal properly.

Also, don't use pliers or vise-grips to remove the plug. That can damage the plug. Instead, use the appropriate hex wrench that comes with your vehicle's basic issue items (BII).

SFC Edward Tull  
Ft Bliss, TX

**Editor's note:** This is a good reminder to not overlook the small details when doing PM!

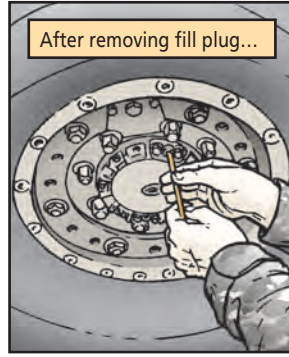

...don't forget O-ring when reinstalling fill plug...



...or leak can develop

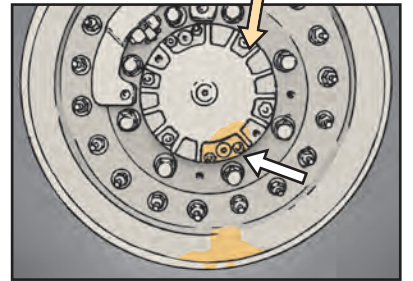

# Override Runs Over Sight Door



**OW!! YOU'RE NOT S'POSED TO USE THAT OVERRIDE SWITCH WHEN MOVING MY ETS. THERE GOES MY SIGHT DOOR MOTOR!**

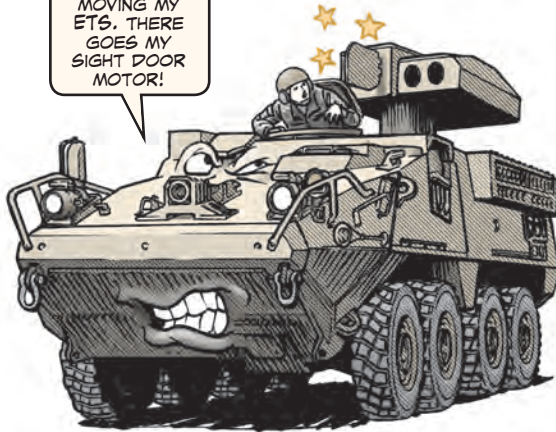

Dear Editor,

M1134 ATGM Stryker crews need to keep their finger off the HATCH OPEN OVERRIDE switch on the commander's control panel (CCP) when using the elevated TOW system (ETS).

Using the override allows the ETS to be moved in azimuth while the commander's hatch is open. The commander's hatch has two locked positions: 60 degrees and 105 degrees. If the commander's hatch is in the 105-degree position, the sight door will run into the hatch, which forces the door closed. This strips the gear teeth in the sight door motor, which prevents the door from opening and closing. Replacing the motor costs about \$10K.

The commander's hatch in the 105-degree position can also damage the TOW launcher and throw off the target acquisition system (TAS) alignment.

Keeping your finger off the OVERRIDE switch will prevent all this damage.

SFC Stephen Brown  
Ft Benning, GA

Using OVERRIDE switch lets sight door bang into commander's hatch

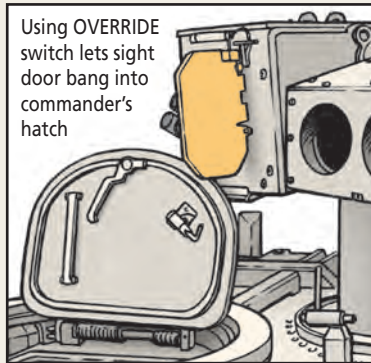

**Editor's note:** *The OVERRIDE switch is not for normal operations. Don't use it as a shortcut or your unit could end up paying out big bucks for repairs.*

# WATCH STEP TO **STAMP OUT** RAMP DAMAGE

**HEY, BUDDY, YOU GOTTA WATCH YOUR STEP WITH THOSE SIZE 22s!**

**YOU KNOW I'M WATCHING OUT FOR THAT PULLEY HOUSING!**

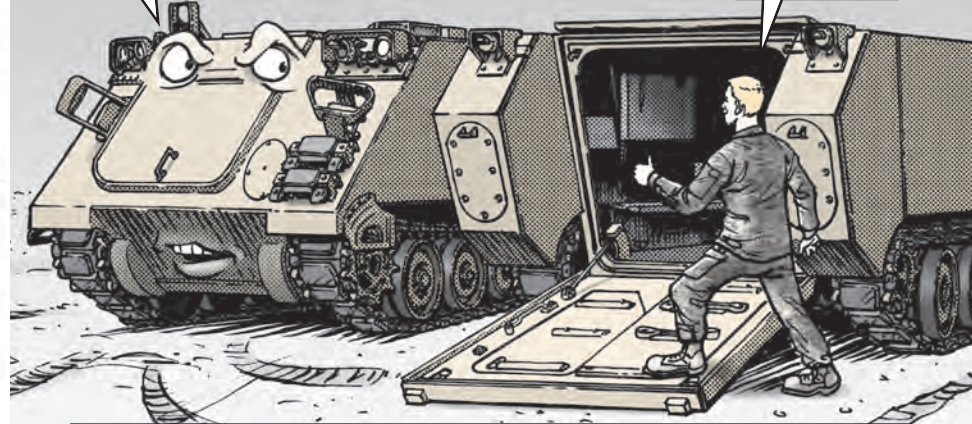

Dear Editor,

The ramps on M113-series vehicles get a lot of use. They also take a lot of abuse. Vehicles can have problems lowering and raising their ramps if the ramp pulley housings are damaged.

Soldiers standing or stepping on the housing can take a toll over time. Also, unsecured gear and equipment can fall on the housing, especially when the vehicle is moving.

Once the housing is damaged, it's just a matter of time until the pulleys inside are also damaged and the wire rope frayed or broken. Then your ramp has serious problems. Even worse, your vehicle is NMC if the ramp no longer raises and lowers.

So crewmen need to watch where they stand and step. Also, make sure all gear and equipment are stowed properly before going on a mission.

SSG Andy Martin  
Ft Irwin, CA

**Editor's note:** *Tread carefully, Soldiers. Your vehicle's ramp will thank you for it!*

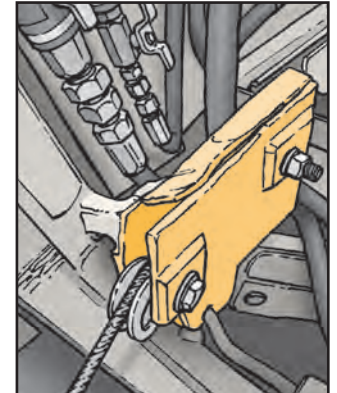

Standing or stepping on pulley housing can lead to pulley and wire rope damage

- Rust Busters Tip of the Month
- 100-Amp Alternator Obsolete
- Out with the Old... In with the New!
- More Miles to Go



Corrosion...

## RUST BUSTERS TIP OF THE MONTH

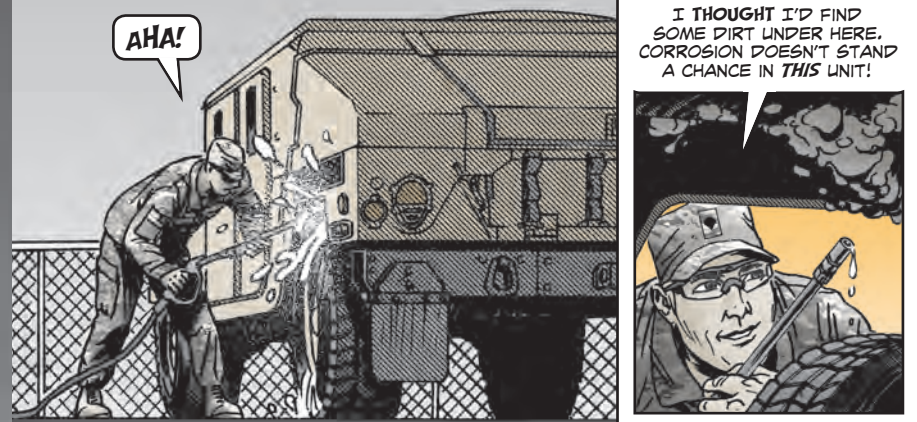

HERE ARE SOME MORE GREAT TIPS TO STOP CORROSION FROM **TAKING OVER** YOUR VEHICLE.



### Water Access

**KEEP YOUR VEHICLE AS DRY AND CLEAN AS POSSIBLE.** CLOSE THE HATCHES, WINDOWS AND OTHER POINTS OF ENTRY WHEN THE VEHICLE'S NOT IN USE. THAT KEEPS OUT DUST AND MOISTURE THAT CAN LEAD TO CORROSION AND MOLD GROWTH.

STANDING WATER ALLOWS MOSQUITOES AND OTHER INSECTS TO BREED. SO ANY TIME YOU FIND STANDING WATER IN YOUR VEHICLE, FIND THE POINT OF ENTRY AND GET IT FIXED **RIGHT AWAY**. THAT MEANS ORDERING MISSING PARTS, LIKE SEALS, IMMEDIATELY.



IF YOU FIND WATER, TAKE THE TIME TO SOAK IT UP WITH RAGS OR USE PRESSURIZED AIR TO DRY IT UP. IT DOESN'T TAKE LONG FOR CORROSION TO GAIN A FOOTHOLD, SO KEEP YOUR VEHICLE TARPED WHENEVER IT'S NOT IN USE.



## Cleaning Guidance

CHECK OUT A COPY OF TB 43-0213, CORROSION PREVENTION AND CONTROL (CPAC) FOR ARMY WHEELED VEHICLES. YOU CAN DOWNLOAD A COPY ON LOGSA'S ETM WEBSITE:

<https://liw.logsa.army.mil/etmapp/#/etm/home>

PAY SPECIAL ATTENTION TO TABLE 1 IN WP 0005 FOR SPECIFIC CLEANERS AND APPLICATIONS:

Application	Cleaning Compound	NSN	Mixing Directions
<b>Fresh Water Wash-down</b>			
Weekly wash or after exposure to salts	Saltbuster wash-down additive	6850-01-470-3319	8 ounces of additive to 1-gal fresh water.
<b>Routine Freshwater Cleaning</b>			
Routine monthly cleaning to remove dirt and salt deposits	General purpose detergent	7930-00-282-9699 (box)	1-oz detergent to 1-gal fresh water
		7930-00-985-6911 (5-gal)	
<b>Heavy Soil Cleaning</b>			
Wash-down to remove heavy soil	Aircraft cleaning compound	6850-01-239-0571 (1-gal)	One part cleaner to four parts fresh water for moderate soil. Use 1:1 ratio for heavy soils.
		6850-01-235-0872 (5-gal)	
		6850-01-248-9828 (15-gal)	
Spot cleaning of heavy soil and stains	Degreasing solvent (low flash point)	6850-01-474-2302 (1-gal)	N/A
		6850-01-474-2309 (5-gal)	
		6850-01-474-2313 (55-gal)	
	Degreasing solvent (high flash point)	6850-01-474-2319 (1-gal)	
		6850-01-474-2317 (5-gal)	
		6850-01-474-2316 (55-gal)	
	Degreasing solvent (high flash point)	6850-01-474-2318 (1-gal)	
		6850-01-474-2320 (5-gal)	
		6850-01-474-2321 (55-gal)	
<b>Battery Compartment Cleaning</b>			
As needed or during PMCS when removing batteries	Sodium bicarbonate	6810-00-297-0092 (50-lb bag)	One part sodium bicarbonate to 16 parts fresh water

MAKE SURE YOU USE ALL REQUIRED PERSONAL PROTECTIVE EQUIPMENT DURING CLEANING.

## Special Attention

SOME AREAS NEED SPECIAL ATTENTION DURING CLEANING...

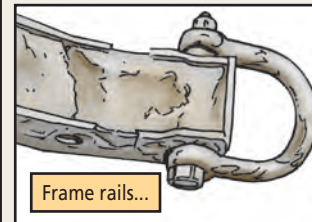

Frame rails...



...tires and fender wells trap mud and water, so check carefully

- Double check fenders that trap water and mud.

- Pay extra attention to tires, front and back, and underbody areas. They are often exposed to contaminants.
- Never expose air cleaners, filters, sensitive electronics or commo equipment to water. Follow the TM's guidance for proper cleaning.

## After Washing

FOLLOW THESE TIPS WHEN YOU'RE FINISHED WASHING...



- Allow at least four hours for drying. When possible, tilt surfaces to allow water to run off.



- Inspect the vehicle for any remaining water or contaminants.
  - Repeat cleaning for areas that are still dirty. Manual cleaning may be necessary.
  - Dry excessive moisture manually if necessary.
  - Difficult to dry areas should be key inspection points. They are more prone to corrosion.
- Inspect the vehicle for any evidence of corrosion or coating damage. Use the checklists in TB 43-0213 for more help.



FMTV...

WHAT'S GOT YOU SO ENERGIZED?

MY NEW 260-AMP ALTERNATOR, THAT'S WHAT!

DUDE, YOU GOTTA DITCH YOUR OLD 100-AMP NOW!

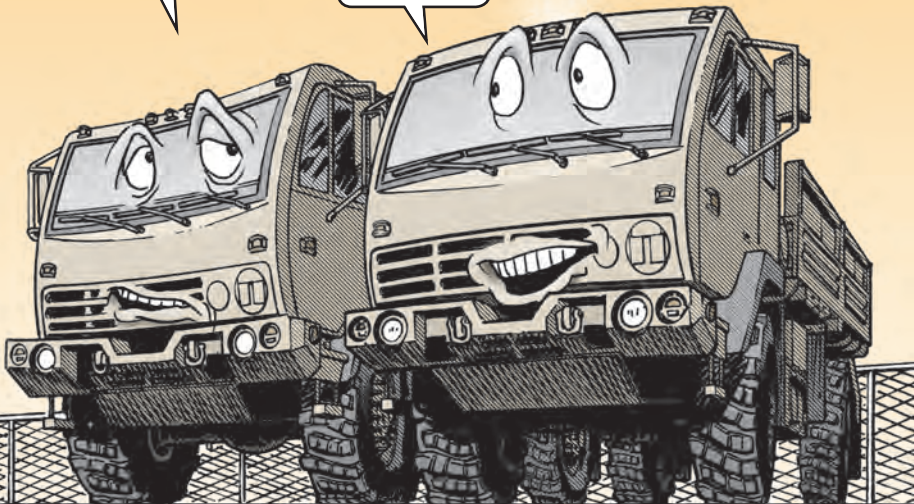

## 100-AMP ALTERNATOR OBSOLETE

The FMTV 100-amp alternator, NSN 6115-01-504-0680, will soon become obsolete. Units should convert to the 260-amp alternator, NSN 2920-01-559-2715.



FMTVS WITH 3126 (SERPENTINE BELT) OR C7 ENGINES WILL NEED THE 260-AMP ALTERNATOR CONVERSION KIT, NSN 6115-01-563-7966, WHICH INCLUDES THE 260-AMP ALTERNATOR.

IF YOUR FMTV HAS A 3116 OR 3126 V-BELT ENGINE, KEEP ORDERING THE 100-AMP ALTERNATOR UNTIL THE SUPPLY RUNS OUT. AFTER THAT, ORDER A CONVERSION KIT, NSN 6115-01-563-7969. THIS KIT INCLUDES A 260-AMP ALTERNATOR.

For maintenance procedures, refer to the Special Purpose Kits work packages in TM 9-2320-391-13&P in IETM EM 0195 (Aug 15).

For supply questions, contact Ted Robinson, FMTV Item Manager, at DSN 786-9308, (586) 282-9308, or email: [ted.f.robinson.civ@mail.mil](mailto:ted.f.robinson.civ@mail.mil)

For maintenance questions, contact Tim Pflueger, FMTV Equipment Specialist, at DSN 786-9401, (586) 282-9401, or email: [timothy.p.pflueger.civ@mail.mil](mailto:timothy.p.pflueger.civ@mail.mil)

PLS...

## Out with the Old...In WITH THE NEW!

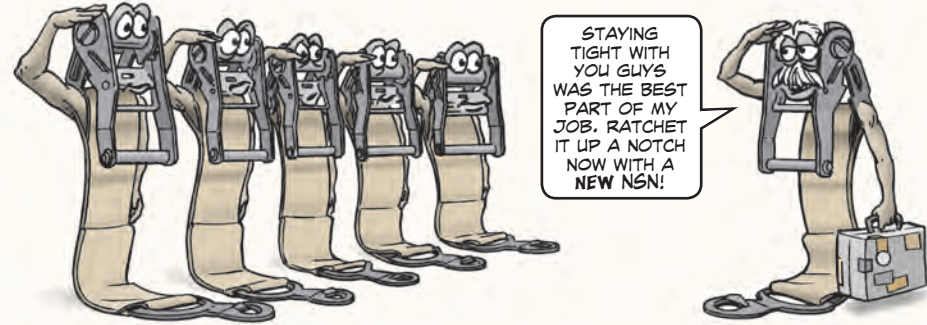

STAYING TIGHT WITH YOU GUYS WAS THE BEST PART OF MY JOB. RATCHET IT UP A NOTCH NOW WITH A NEW NSN!

You knew this day would come. The old reliable M3/M3A1CROP flatrack's ratchet strap now has a new NSN. Order it with NSN 5340-01-663-1029 (PN 12629440).

The old NSN 5340-01-504-2426, which is shown as Item 1 in the Basic Issue Items (BI) on Page C-1 of TM 9-3990-260-14&P (Jul 01, w/Ch1, Nov 06), is no longer valid. Orders submitted with the old NSN are automatically canceled because the item is terminal and stock has been exhausted.

M915A5 Tractor Truck...

## More Miles to Go



IS IT TIME YET? IS IT TIME? IS IT? IS IT?!

BE PATIENT, BIG FELLA. YOU CAN GO A COUPLA' THOUSAND MORE MILES BEFORE ANOTHER OIL CHANGE.

The M915A5 can now go 12,000 miles between oil changes, thanks to recent corrections made in the truck's service intervals.

TACOM Maintenance Information (MI) message #17-038 says the correct oil change interval for the engine, transmission, coolant and rear differentials is now 12,000 miles or annually, whichever comes first.

TACOM also extended the life of the M915A5's air filter because it's self-cleaning. Replace it only when the air filter indicator gauge says the filter can't clean itself.

Make a note of the new mileage interval until TM 9-2320-426-13&P in IETM EM 0308 (Aug 14) is updated. For more info, check out TACOM MI 17-308 at:

<https://tulsa.tacom.army.mil/Maintenance/message.cfm?id=MI17-038.html>

- Bucket Lube Stops Squeakers
- Ain't That a Stick in the Eye!
- Get the Axle Lube Lowdown



966H Wheel Loader...

## BUCKET LUBE STOPS SQUEAKERS

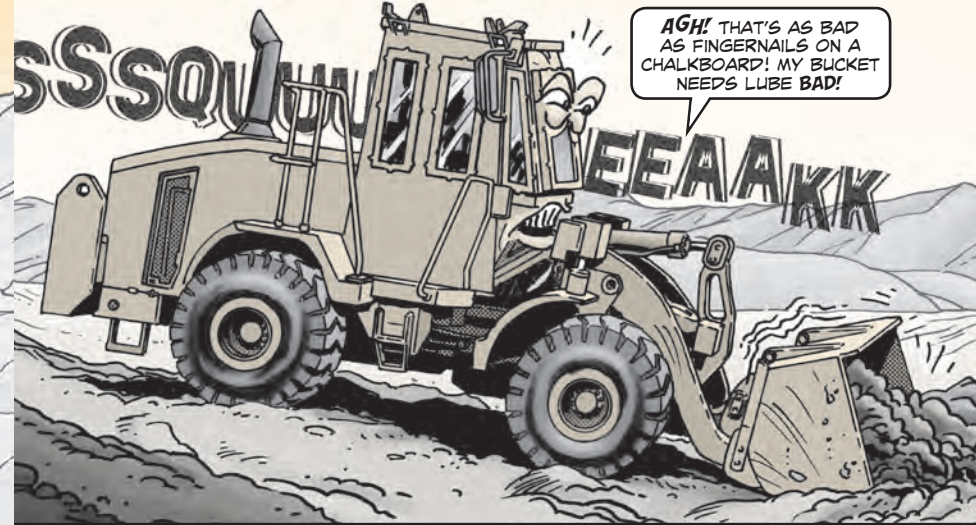

**O**PERATORS, A LOUD SQUEAKING NOISE AND UNLUBED PIVOT PINS AND LIFT ARMS ON YOUR 966H WHEEL LOADER'S BUCKET ARE PROBABLY RELATED.

**WITHOUT LUBE, THE BUCKET STARTS SQUEAKING WHENEVER IT'S RAISED OR LOWERED. YOU'LL KNOW THE PROBLEM IS GETTING BAD WHEN THE BUCKET STARTS MOVING ERRATICALLY DURING OPERATION.**

THE BUCKET'S BANK OF GREASE FITTINGS IS LOCATED ON THE DRIVER'S SIDE OF THE VEHICLE AT GROUND LEVEL.

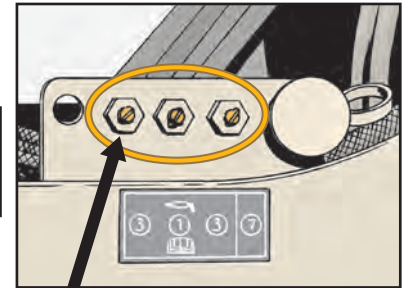

**EVERY WEEK, GIVE EACH OF THE FITTINGS THREE TO FIVE PUMPS OF GREASE.**



# AIN'T THAT A STICK IN THE EYE!

WHAT'S GOIN' ON? IT'S NOT NATIONAL PIRATE DAY AGAIN, IS IT?

NAH! JUST FORGOT THE TURN-TABS ON MY HUSKY'S TRANSMISSION FILTER ACCESS COVER!



YOU CAN GET A REAL EYEFUL FROM THE LOCKING PINS THAT HOLD THE ACCESS DOOR IN PLACE ON THE HUSKY'S TRANSMISSION FILTER!

A LOCKING PIN THAT'S LEFT STICKING STRAIGHT OUT CAN POKE YOU IN THE EYE OR JAB YOU IN THE FOREHEAD AS YOU LEAN FORWARD TO LOOK AT THE FILTER.

After opening access door, push back locking pins...

...or you may get poked in the eye!



SO AFTER OPENING THE ACCESS DOOR, MAKE SURE YOU PUSH THE LOCKING PINS BACK IN PLACE BEFORE YOU CHECK THE FILTER.

IT SURE BEATS A POKE IN THE EYE!



OH, DON'T TELL ME...

I DON'T WANNA TALK ABOUT IT.

[Click here for a copy of this article to save or email.](#)

# SQUEEEEAH!!!!

HOLY COW! WHAT'S GOIN' ON?!

THAT'S WHAT HAPPENS WHEN YOU DON'T LUBE MY FRONT AXLE HOUSING!



## GET THE AXLE LUBE LOWDOWN

OPERATORS, THE GREASE FITTINGS ON YOUR 6K AND ATLAS FORKLIFT'S FRONT AXLE NEED LUBE, AND **LOTS OF IT!**

LUBE ALLOWS THE KNUCKLE, THRUST WASHER AND AXLE TO WORK IN TANDEM FOR SMOOTH OPERATION.

WITHOUT LUBE, THE THRUST WASHER BETWEEN THE KNUCKLE AND HOUSING DETERIORATES AND BREAKS APART. THE END RESULT IS A FORKLIFT IN NEED OF AN AXLE HOUSING REPLACEMENT. TALK ABOUT EXPENSIVE DOWNTIME!



Axle housing...

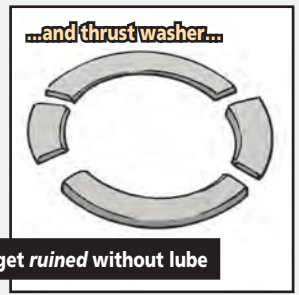

...and thrust washer...

...get ruined without lube



SO REMEMBER TO LUBE THE FRONT AXLE'S FITTING WITH FOUR OR FIVE SHOTS OF GREASE DURING SCHEDULED MAINTENANCE.

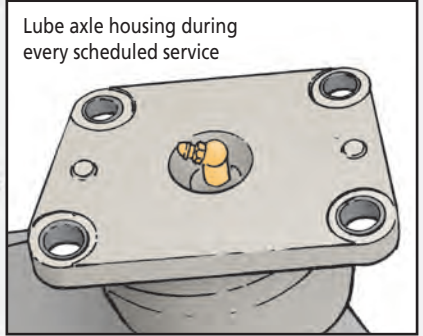

Lube axle housing during every scheduled service

[Click here for a copy of this article to save or email.](#)

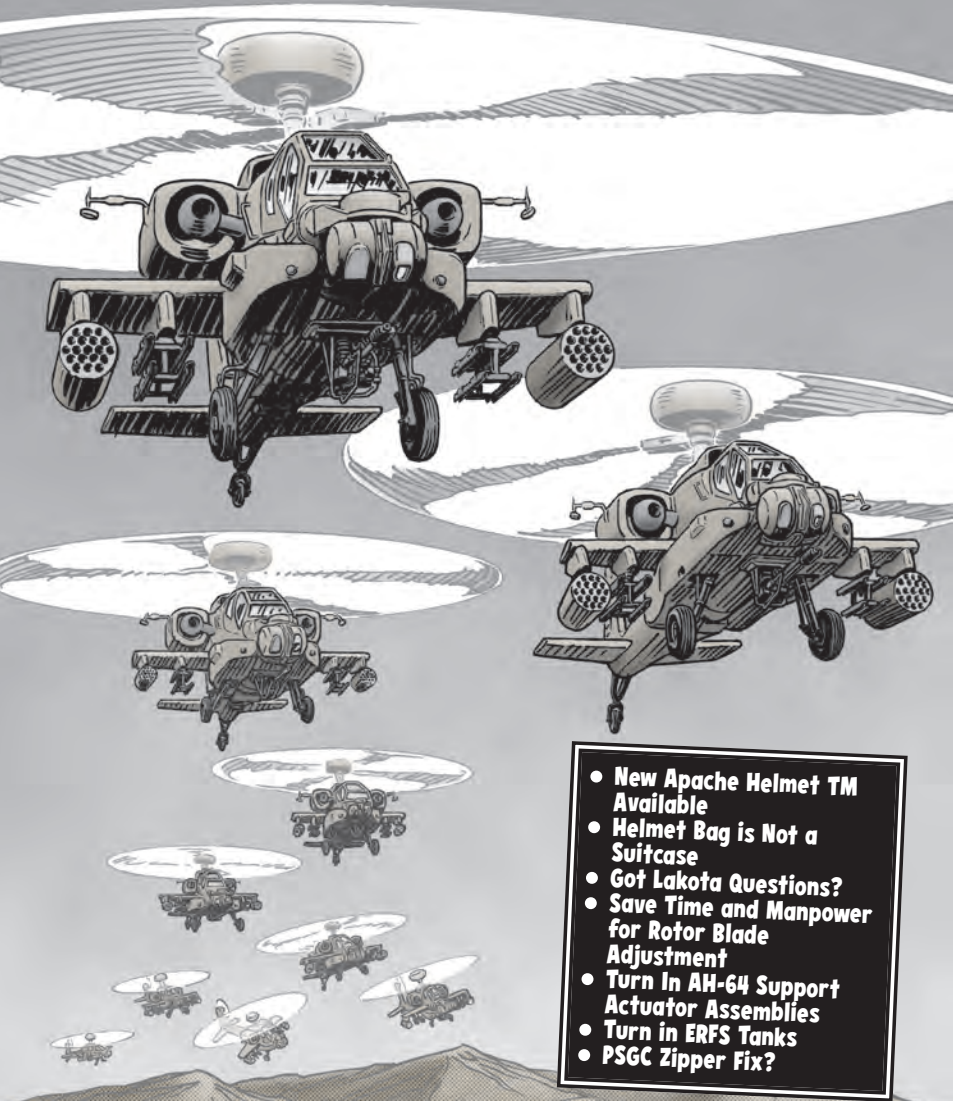

- New Apache Helmet TM Available
- Helmet Bag is Not a Suitcase
- Got Lakota Questions?
- Save Time and Manpower for Rotor Blade Adjustment
- Turn In AH-64 Support Actuator Assemblies
- Turn in ERFs Tanks
- PSGC Zipper Fix?

## New Apache Helmet TM Available

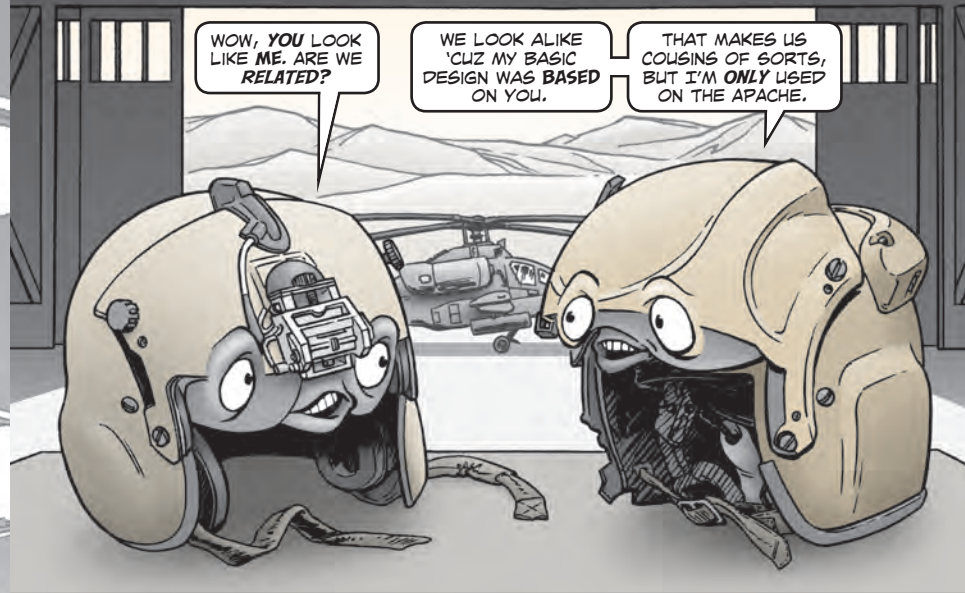

WOW, YOU LOOK LIKE ME. ARE WE RELATED?

WE LOOK ALIKE 'CUZ MY BASIC DESIGN WAS BASED ON YOU.

THAT MAKES US COUSINS OF SORTS, BUT I'M **ONLY** USED ON THE APACHE.

**P**ILOTS, TM 1-1680-392-13&P FOR THE AH-64E'S APACHE AVIATOR INTEGRATED HELMET (AAIH) IS NOW AVAILABLE ON THE LOGSA ETM WEBSITE:  
<http://liw.logsa.army.mil/etmapp/#/etm/home>

DOWNLOAD A COPY NOW SO YOU CAN DO THE PM NEEDED TO KEEP YOUR HELMET IN TIP-TOP SHAPE.

HERE ARE THE AVAILABLE AAIH HELMET SIZES:



Size	NSN 8415-	PN
XXS	01-621-8150	IH-494A-00
XS	01-621-8146	IH-488A-00
S	01-621-8145	IH-482A-00
M	01-621-8072	IH-476A-00
L	01-621-8069	IH-470A-00
XL	01-621-8064	IH-464A-00

FOR D-MODEL APACHES, THE INTEGRATED HELMET AND DISPLAY SIGHT SYSTEM (IHADSS) IS THE HELMET TO USE. TM 9-1270-233-23&P HAS WHAT YOU NEED TO MAINTAIN THE IHADSS HELMET.

# Helmet Bag is Not a Suitcase



HALP!  
I'M TOO STUFFED!

HEY! I CAN'T HANDLE ALL THIS STUFF.



THEY'RE CALLED 'HELMET BAGS' FOR A REASON, SOLDIERS! ONLY THE HELMET GOES IN THE BAG!

FOR EXAMPLE... IF YOU PUT YOUR COLD WEATHER JACKET, GLOVES, FLASHLIGHT AND CHECKLIST IN THE BAG, THEN DRAPE IT WITH COMMUNICATIONS CORDS, A COUPLE OF FLOOR TETHERS AND A VEST BETWEEN THE HANDLES...

...THE NEXT TIME YOU TOSS IT OVER YOUR SHOULDER OR CARRY IT AROUND LIKE A SUITCASE, ALL THAT EXTRA WEIGHT WILL RIP THE HANDLES OFF.

NOT ONLY THAT, THE EXTRA ITEMS COULD DAMAGE THE HELMET THAT'S DESIGNED TO PROTECT YOUR NOGGIN IN AN AIRCRAFT EMERGENCY!



OOHHH... I THINK YOU CRACKED MY SHELL!

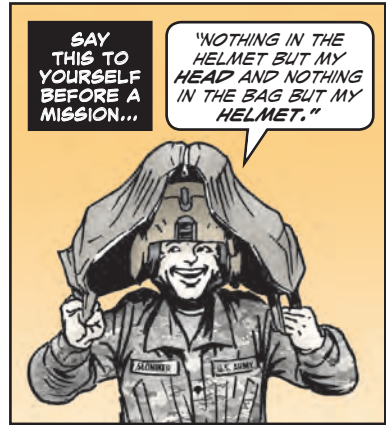

SAY THIS TO YOURSELF BEFORE A MISSION...

"NOTHING IN THE HELMET BUT MY HEAD AND NOTHING IN THE BAG BUT MY HELMET."

CREWMEMBERS, THE HELMET BAG, NSN 8415-01-406-6909, FOR THE INTEGRATED HELMET AND DISPLAY SIGHTING SYSTEM (IHADSS), THE APACHE AVIATOR INTEGRATED HELMET (AAIH) AND THE AIRCREW INTEGRATED HELMET SYSTEM (AIHS), IS DESIGNED TO CARRY YOUR AIRCRAFT'S HELMET TO AND FROM THE FLIGHT LINE.

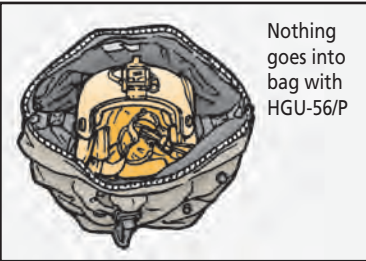

Nothing goes into bag with HGU-56/P

A FEW ACCESSORIES LIKE THE DISPLAY VISOR ASSEMBLIES, SUNGLASSES AND FLIGHT GLOVES THAT FIT INTO THE OUTSIDE POCKETS OF THE HELMET BAG ARE PERMITTED, TOO.

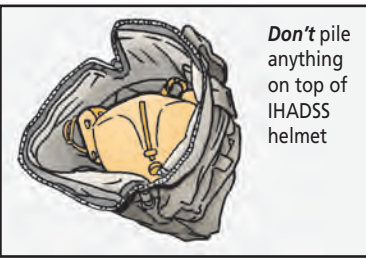

Don't pile anything on top of IHADSS helmet

**BUT THE HELMET BAG IS NOT A SUITCASE, A BACKPACK OR A STORAGE BAG FOR CARRYING CHECKLISTS, CALCULATORS, NOTEPADS AND MAPS.**

PACKING THE HELMET BAG WITH EXTRA ITEMS STRAINS THE HANDLES. THE END RESULT IS TORN HANDLES.

## Got Lakota Questions?

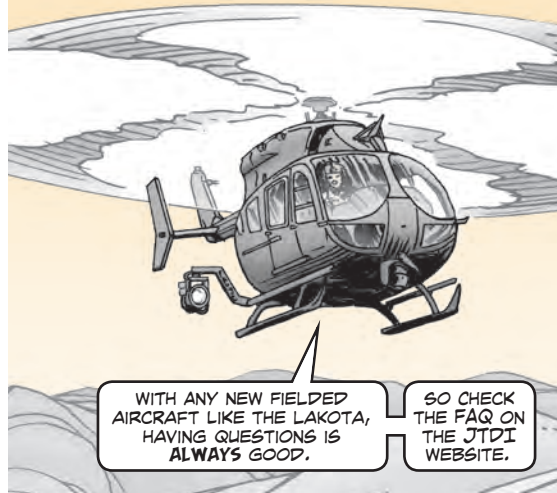

PILOTS AND MAINTAINERS, THE LAKOTA HEADSHED IS LOOKING FOR FREQUENTLY ASKED QUESTIONS (FAQs) THAT WILL BE POSTED ON THE JTDI WEBSITE TO HELP OTHER LAKOTA USERS.

TO SUBMIT FAQs FOR CONSIDERATION, EMAIL THEM TO MICHAEL BROOKS OR JOHNNY ELEY AT:  
[michael.w.brooks28.civ@mail.mil](mailto:michael.w.brooks28.civ@mail.mil)  
[johnny.s.eley.civ@mail.mil](mailto:johnny.s.eley.civ@mail.mil)

TO VIEW PREVIOUS FAQs, GO TO THE JTDI WEBSITE AT:  
<https://www.jtdi.mil>  
 AT THE SITE, CLICK ON THE UHPO TAB, THEN CLICK UH-72A. THEN SCROLL DOWN AND CLICK ON UH-72A FREQUENTLY ASKED QUESTIONS.

WITH ANY NEW FIELDPED AIRCRAFT LIKE THE LAKOTA, HAVING QUESTIONS IS ALWAYS GOOD.

SO CHECK THE FAQ ON THE JTDI WEBSITE.

# Save Time and Manpower for Rotor Blade Adjustment

THERE'S GOTTA BE A BETTER WAY TO DO THIS!

TRYING TO HOLD UP THE BLADE WHILE ONE OF YOU GUYS ADJUSTS THE PC LINKS IS *KILLING* MY ARMS!

IT'S A REAL STAMINA TEST. THAT'S FOR SURE!

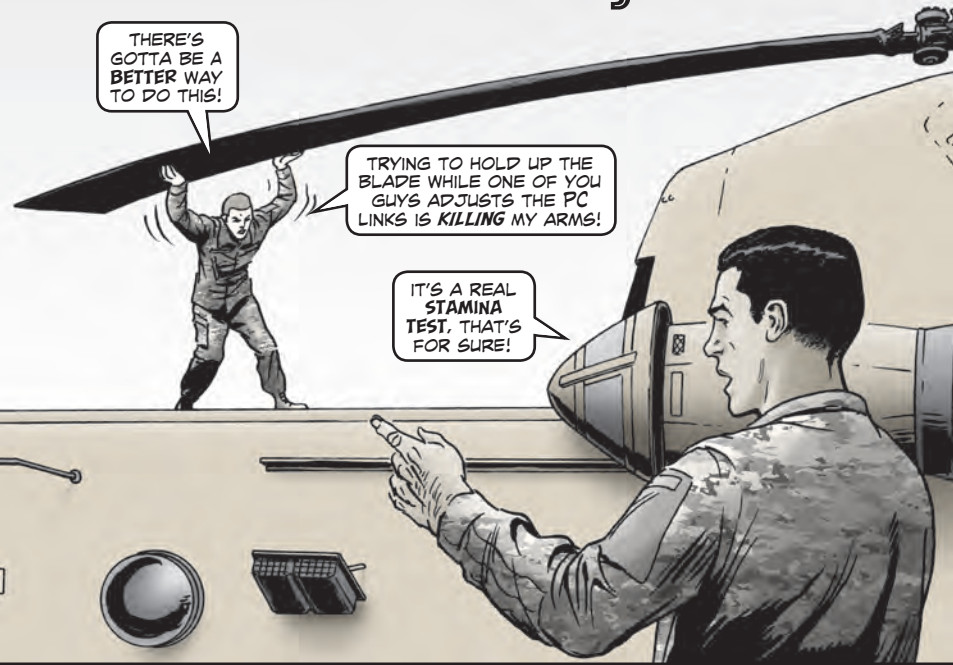

MECHANICS, HOLDING THE ROTOR BLADES UP WHILE ADJUSTMENTS ARE BEING MADE CAN BE **AWKWARD AND TIRESOME.**

SIMPLIFY THE JOB AND REDUCE THE MANPOWER NEEDED BY MAKING AND USING A **ROTOR BLADE STAND.**

THE TOOL HOLDS THE BLADE IN PLACE WHILE THE PITCH CHANGE LINKS ARE ADJUSTED.



IF YOU HAVE YOUR COMMANDER'S APPROVAL, HERE'S WHAT YOU'LL NEED TO MAKE THE STAND.

- Angle aluminum, 2x2-in, NSN 9540-00-231-9911
- Lumber, 2x4-in, NSN 5510-00-267-2283
- Machine bolt (27 ea.), PN AN5-7A, NSN 5306-01-450-4885
- Flat washer (54 ea.), PN NAS1149F0563P, NSN 5310-00-167-0820
- Self-locking nut (27 ea.), PN MS21044N5, NSN 5310-00-088-0553
- Felt strip, NSN 8305-00-812-2360

## ASSEMBLE THE STAND LIKE THIS:

WHEN USING THE STAND, MAKE SURE YOU PUT THE LEGS **ONLY** ON THE REINFORCED SEAMS OF THE FUSELAGE.

THAT WAY THE STAND WON'T DENT OR TEAR THE AIRCRAFT'S SKIN.

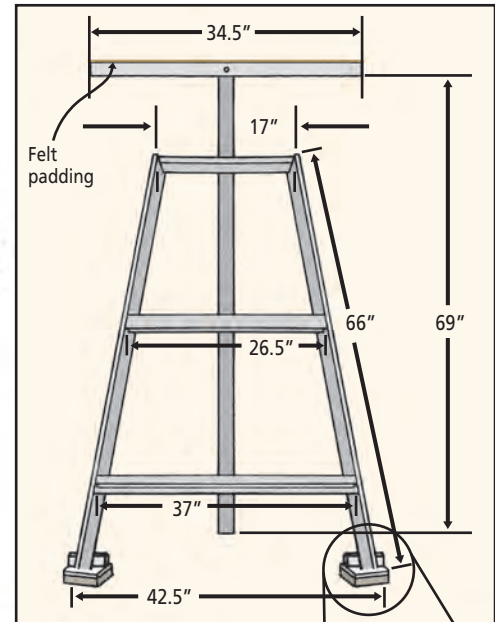

**NEVER** TIGHTEN THE HARDWARE ATTACHING THE BLADE SUPPORT TO THE VERTICAL BEAM. THE BLADE SUPPORT **MUST** BE ABLE TO TILT TO FIT THE ANGLE OF THE ROTOR BLADE.

Don't tighten hardware attaching blade support

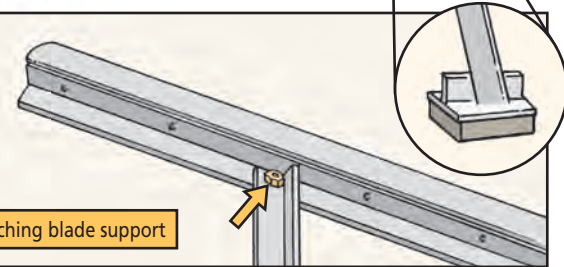

TO USE THE TOOL, LIFT THE BLADE AND PLACE THE STAND UNDER THE BLADE TOWARD THE TIP. THEN LOWER THE BLADE ONTO THE STAND.

WHEN ADJUSTMENTS ARE COMPLETE, LIFT THE BLADE, REMOVE THE STAND AND LOWER THE BLADE.

## Turn In AH-64 Support Actuator Assemblies

If you have unserviceable Apache support actuators, NSN 1615-01-527-3781 (PN 7-311525062-19), lying around the hangar or in the back shops, turn them in for repair to Plant 7001/RIC BR4, Red River Army Depot, TX 75501. For more info, contact Valerie Lugo, DSN 897-6973, (256) 313-6973 or email:

[valerie.a.lugo2.civ@mail.mil](mailto:valerie.a.lugo2.civ@mail.mil)

# Turn in ERF5 Tanks

HEY, BUDDY, I NEED YOUR HELP! I JUST FOUND OUT MY 230 GALLON ERF5 TANKS ARE NON-CRASHWORTHY AND NON-AIRWORTHY.

WE GOTTA TURN 'EM IN ASAP!

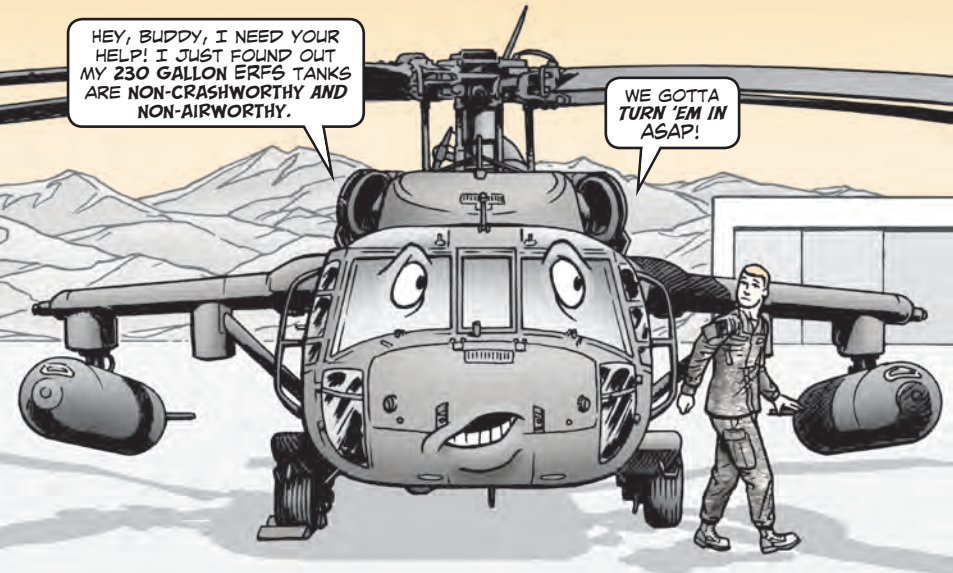

**M**echanics, if your unit has 230-gal extended range fuel system (ERF5) tank kits, NSN 1560-01-257-5817, under (LIN E20312), turn them in **NOW**.

A RECENT DECISION SUPPORT TOOL (DST) REPORT REVEALED THAT SOME ARMY UNITS STILL HAVE ERF5 TANKS ON-HAND. THE HEADSHPED WANTS ALL OF THOSE 230-GAL TANKS TURNED IN BECAUSE THEY'RE NON-AIRWORTHY AND NON-CRASHWORTHY.

FOR DETAILED DISPOSITION INSTRUCTIONS, A COPY OF THE ENVIRONMENTAL PROTECTION SHEET AND SPECIAL PACKAGING INSTRUCTIONS, GO TO DST AND SLAMIS AT: <https://www.slamis.army.mil>

THE 200-GAL CRASHWORTHY EXTENDED FUEL SYSTEM (CEF5) KIT, NSN 1560-01-628-8976, USES THE SAME LIN. HOWEVER, LIKE IT SAYS IN THE DISPOSITION INSTRUCTIONS, DON'T TURN IN THOSE KITS.

FOR MORE INFORMATION, CONTACT PEO AVIATION'S ERIC ZUROWSKI (256) 313-1310, OR ADAM GARCIA (256) 313-3779. OR EMAIL THEM AT: [eric.b.zurowski.civ@mail.mil](mailto:eric.b.zurowski.civ@mail.mil) [adam.j.garcia2.civ@mail.mil](mailto:adam.j.garcia2.civ@mail.mil)

## PSGC Zipper Fix?

Having trouble with the bead slider pull tab coming off the center zipper tab on your GEN I, II or III, primary survival gear carrier (PSGC) body armor overlay system (BAOS)? The fix is in WP 0118 of TM 1-1680-377-13&P-1 (Mar 12, w/Ch2, Jun 16).

## INTRODUCING: THE NIGHT KNIGHT

WHEN THE SUN GOES DOWN AND SHADOWS FALL OVER HESTIA CITY, A SOLITARY FIGURE OF JUSTICE SPRINGS INTO ACTION, PROTECTING THE CITY FROM THOSE WHO WOULD CAUSE HARM.



C'MON, YOU MOOKS! WE GOTTA GET OUTTA HERE QUICK-LIKE!

Willains!

AWW...



NUTS!



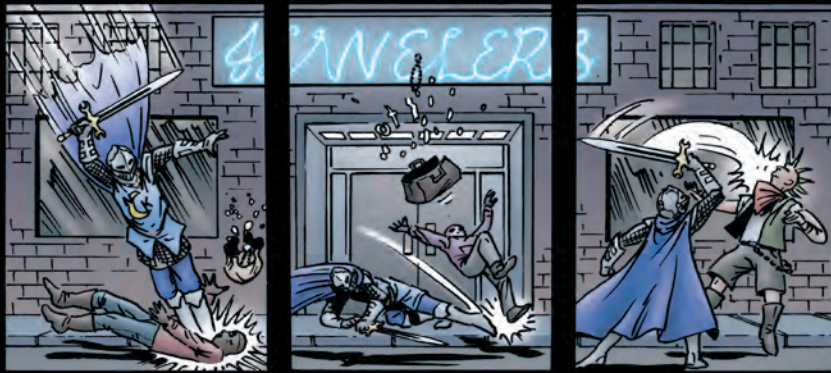

CROOKS, CRIMINALS AND THIEVES KNOW HIM SIMPLY AS "THE SHADOW'S SCOURGE" BUT THE GOOD PEOPLE OF HESTIA CITY KNOW HIM AS

# THE NIGHT KNIGHT

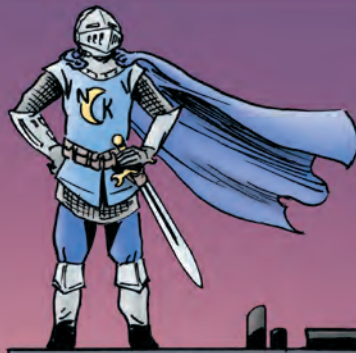

BUT I KNOW HIM AS **STEVE REEVES**, THE BILLIONAIRE OWNER OF REEVES INDUSTRIES. THAT'S HIS DAY JOB... WELL, PART OF IT ANYWAY.

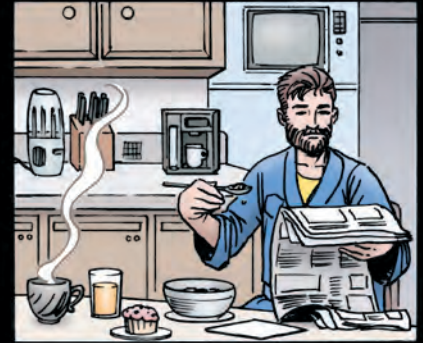

BESIDES RUNNING HIS COMPANY, A MAN WHO ROUTINELY SAVES THE CITY HAS TO STAY IN GREAT SHAPE...



...KEEP UP WITH CURRENT EVENTS AND TRACK BOTH LOW LEVEL ROBBERS...



IT'S JUST BEEN REPORTED THAT **MANN E. PRANKS** HAS ESCAPED FROM NORTH POINT ASYLUM. HE WAS LAST SEEN HEADING...

...AND CRIMINAL MASTERMINDS.



SUSPECT REMAINS AT LARGE

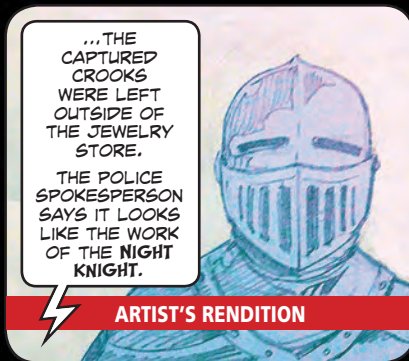

ARTIST'S RENDITION

BUT ONE OF THE MOST IMPORTANT THINGS THAT STEVE, ~~SAHEM~~ THE NIGHT KNIGHT, HAS TO DO IS PREVENTIVE MAINTENANCE ON ALL OF THE EQUIPMENT HE USES TO PROTECT HESTIA CITY.

PM IS THE REAL SECRET TO HIS SUCCESS.



PM ON THE NIGHT KNIGHTMOBILE GAVE HIM THE EXTRA SPEED HE NEEDED TO SAVE THE MAYOR OF HESTIA CITY FROM FACE CARD'S EXPLOSIVE-FILLED WAREHOUSE TRAP.

HE USES PM TO KEEP THE NIGHT KNIGHT COPTER IN TIP-TOP SHAPE.

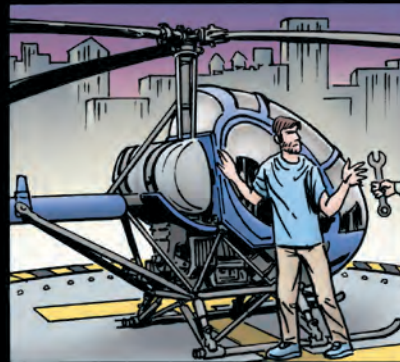

THAT'S HOW HE WAS ABLE TO RESCUE THE POLICE COMMISSIONER, WHO'D BEEN KIDNAPPED BY EVIL EMU...

...FROM THE ROOF OF A BUILDING THAT WAS BEING DEMOLISHED.



AND PM MAKES SURE THAT THE FUNCTIONAL BELT IS READY TO BAIL STEVE OUT OF ANY TIGHT SPOTS HE GETS HIMSELF INTO.



LIKE THE TIME HE HAD TO USE HIS NIGHT KNIGHT KNOCK-OUT GAS TO *SUBDUE* THE MALEFICENT MILKMAN'S HENCHMEN WHEN THEY HAD HIM CORNERED IN THEIR CREEPY, ABANDONED DAIRY FARM HIDEOUT.



AS A MATTER OF FACT, EVERY TIME NIGHT KNIGHT HAS COME TO THE RESCUE OF THE CITIZENS OF HESTIA CITY, HE'S HAD TO USE HIS GADGETS TO DO IT. HE PERFORMS HIS PM ON TIME, ALL THE TIME AND BY THE BOOK TO MAKE SURE THAT HIS EQUIPMENT IS ALWAYS READY.



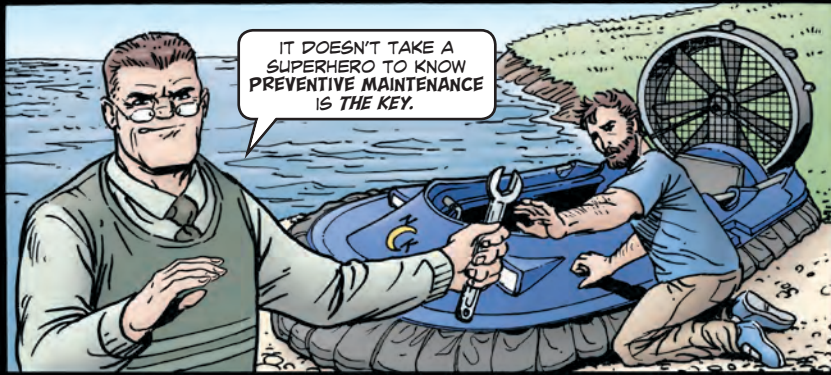

IT DOESN'T TAKE A SUPERHERO TO KNOW PREVENTIVE MAINTENANCE IS THE KEY.

IF YOU TAKE GOOD CARE OF YOUR EQUIPMENT, IT'LL TAKE GOOD CARE OF YOU...



...SO YOU CAN TAKE GOOD CARE OF YOUR CITY!

# PS SMALL ARMS

- Is There Minimum Length for Action Spring?
- Wrong Trigger Lever Stop Assembly!
- Sniper Items Combined
- Subscribe to Magazine PM
- Heat Shield Damage?

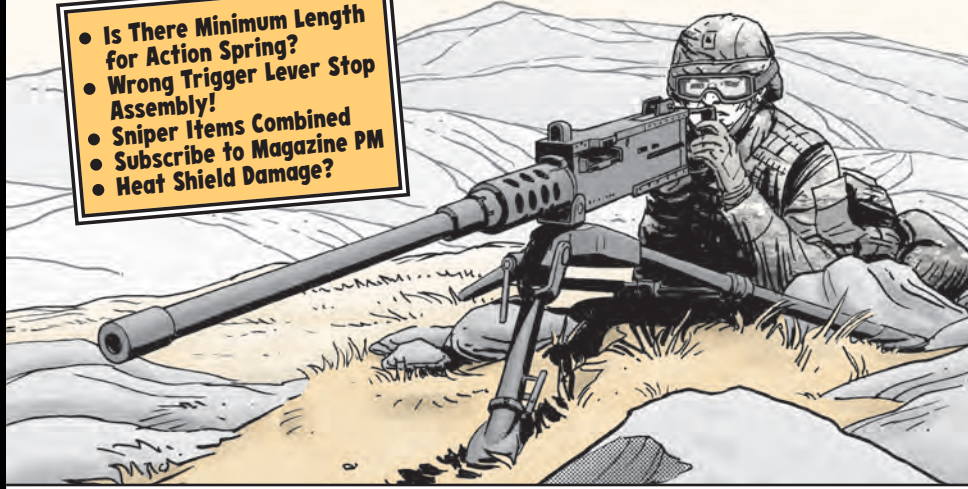

# CBRN

- Protection from the Cold
- Caps, Plugs, Bags? We've Got You covered!
- Gas Problems? Try These Industrial Solutions!
- THE WORD on Vehicle Support Stands



ALSO FEATURING TOOLS

# Is There a Minimum Length for Action Spring?



LOOKS LIKE YOUR ACTION SPRING IS GETTING TOO SHORT. GUESS WE NEED TO GET YOU A NEW ONE.

NOPE. THE ARMY DID AWAY WITH THE MINIMUM STANDARD. I'M GOOD TO GO.



Dear Half-Mast,  
Is there a minimum length for the M16 rifle and M4 carbine action springs? TM 9-1005-319-23&P says there is, but we've heard that requirement has been abolished. What's the deal?

SPC J.B.

Dear Specialist,

TACOM LCMC Maintenance Information (MI) message 16-013 did away with the minimum length requirement for M16 and M4 action springs:

<https://tulsa.tacom.army.mil/Maintenance/message.cfm?id=MI16-013.html>

But there is still a maximum length requirement: 13 1/2 inches for the M16's and 11 1/4 inches for the M4's. Replace the M16 spring with NSN 5360-00-992-6665 and the M4 spring with NSN 5360-01-233-8617.

Action springs no longer have minimum length standard...

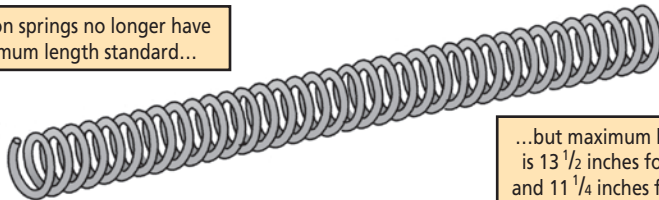

...but maximum length is 13 1/2 inches for M16 and 11 1/4 inches for M4

Don't try to adjust the length of springs by stretching them. That just weakens the spring.

Don't interchange springs between weapons. That can lead to malfunctions.

Always inspect springs for cracks, kinks or broken strands.

*Half-Mast*

M2A1 Machine Gun...

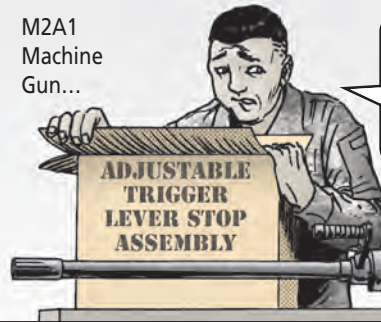

WAIT A MINUTE! THAT'S FOR AN M2. THAT WON'T WORK FOR ME.

# WRONG TRIGGER LEVER STOP ASSEMBLY!

Dear Half-Mast,  
We ordered an adjustable trigger lever stop assembly (Item 22 in Fig 1 of TM 9-1005-347-23&P) for our M2A1 machine gun. It turned out to be the stop assembly for the M2, which doesn't work for the M2A1. Can you help?

CW3 S.F.

Dear Chief,

That's what we're here for.

Until this mistake is corrected in the TM, you'll need to order the M2 adjustable trigger bar stop assembly, NSN 1005-00-726-5212. When you get the adjustable trigger bar stop assembly, remove the flat adjustable trigger lever stop nut and the knurled plain nut. These aren't used on the M2A1.

PS will let you know when the M2A1 trigger lever adjustable stop is available as an assembly.

*Half-Mast*

# SNIPER ITEMS COMBINED



SNIPERS NOW HAVE LESS TO CARRY.

THE ADVANCED WEATHER STATION, NSN 6685-01-560-0128, AND THE ADVANCED BALLISTIC CALCULATOR, NSN 7021-01-571-1574, HAVE BEEN COMBINED INTO THE ADVANCED BALLISTIC WEATHER METER, NSN 6660-01-664-2388.



FOR MORE INFORMATION ABOUT ADVANCED SNIPER ACCESSORIES, CONTACT EUGENE MEADE AT DSN 786-1253, (586) 282-1253, OR EMAIL: [eugene.v.meade2.civ@mail.mil](mailto:eugene.v.meade2.civ@mail.mil) OR MICHAEL PRICE AT DSN 786-1252, (586) 282-1252, OR EMAIL: [michael.b.price.civ@mail.mil](mailto:michael.b.price.civ@mail.mil)

# Subscribe to Magazine PM



No matter how well you maintain your M16 rifle or M4/M4A1 carbine, it won't be much good without bullets. That's why it's important you subscribe to magazine PM. When you PMCS your M16 or M4, also PMCS your magazines like this:

### Check all magazines for dents, cracked welds, and corrosion.

If a magazine has more than minor dents or corrosion, get a new one. No use taking chances.



### Eyeball the magazine's feed lips.

If they're bent, rough or gouged, get a new magazine. You can check if the feed lips are OK with the wear check tool that comes with NSN 5120-01-660-5329.



Feed lips bent?

IF THE MAGAZINE'S SPRING AND FOLLOWER HAVE COME APART, DON'T TRY TO REATTACH THEM. GET A NEW MAGAZINE.



Never stretch the spring to try to make it work better. That just ruins the spring.

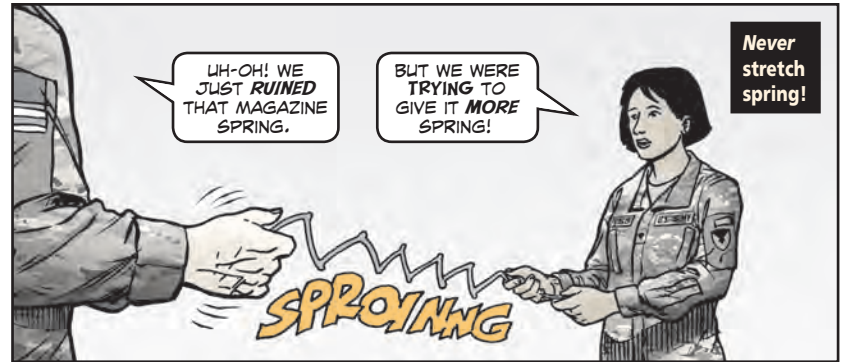

Never use a speed loader or jam the feed lips against a table edge or anything hard while loading a magazine. That bends the feed lips and ruins the magazine.



To load a magazine, use the 10-round stripper clip and magazine filler found in each bandoleer to load 30 rounds. With the magazine filler in place, push with your thumb on the rear of the top cartridge until all 10 rounds are below the feed lips. Remove the empty stripper clip while holding the magazine filler in place. Repeat until all three 10-round clips are loaded.

To make the job even easier, get the loading tool, NSN 1005-01-660-5277.

Use stripper clip and magazine filler to load magazines

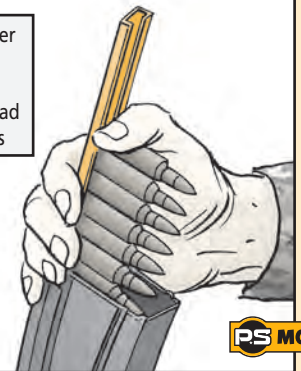

PS MORE

But you do want to clean the magazines often, especially in the desert where sand can clog them. Just take the magazine apart and run a clean cloth through each tube until all the sand or dirt is gone. Wipe off dirt from the follower and spring.

Run a cloth through magazine tube to clean out dirt

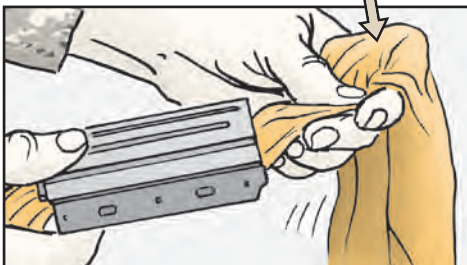

But don't lube any part of the magazine, including the spring. That will just attract more dirt.

THAT'S RIGHT! NO PART OF ME NEEDS LUBE. I JUST NEED TO BE CLEANED.

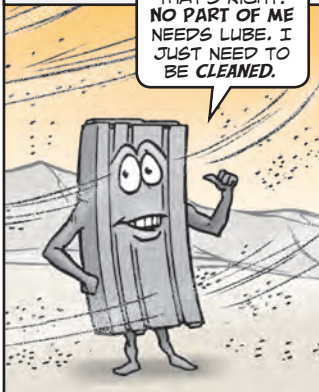

IF YOU'RE OPERATING IN THE DESERT, YOU MIGHT WANT TO KEEP MAGAZINES IN SEALED BAGS AS MUCH AS POSSIBLE. NSN 1005-00-193-8306 BRINGS ME...



M240B Machine Gun...

# HEAT SHIELD DAMAGE?

Dear Half-Mast,  
How damaged can the M240B machine gun's heat shield be before it must be replaced? We are having a disagreement about this.  
C.D.

WP 0020 00-4 in TM 9-1005-313-10 SAYS IF THE HEAT SHIELD IS MISSING OR BROKEN TO SUCH AN EXTENT THAT IT ALLOWS CONTACT WITH METAL, IT NEEDS TO BE REPLACED. IF IN DOUBT, REPLACE IT.

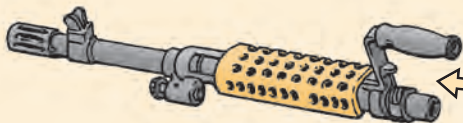

Heat shield so cracked it allows contact with metal? Replace it



M26, M12A1 Decons...

# PROTECTION FROM THE COLD

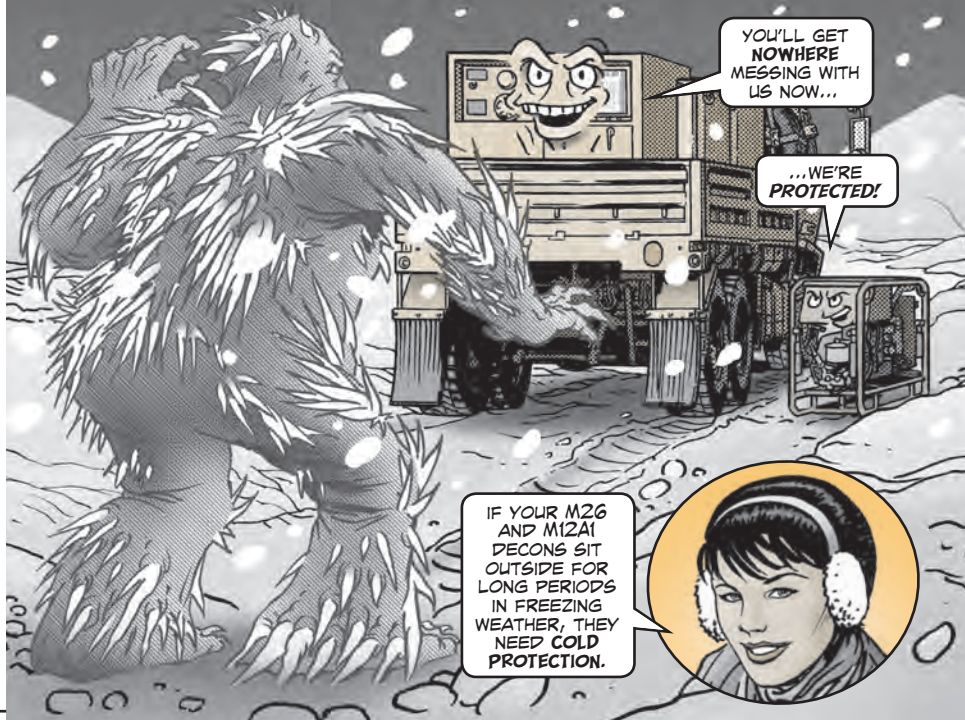

YOU'LL GET NOWHERE MESSING WITH US NOW...

...WE'RE PROTECTED!

IF YOUR M26 AND M12A1 DECONS SIT OUTSIDE FOR LONG PERIODS IN FREEZING WEATHER, THEY NEED COLD PROTECTION.

IT'S ALMOST IMPOSSIBLE TO DRAIN OUT ALL WATER FROM THE M26 AND M12A1s.

THAT WATER CAN FREEZE AND DAMAGE THINGS LIKE TANKS AND PUMPS, WHICH ARE EXPENSIVE REPAIRS.

STOP COLD IN ITS TRACKS LIKE THIS:

**FOR THE M26...**  
...FREEZE PROTECTION IS EASY. JUST RUN ANTIFREEZE THROUGH IT.

**FOR THE M12A1...**  
...FOLLOW THE INSTRUCTIONS IN WP 11 IN TM 3-4230-237-10, OPERATOR MAINTENANCE OPERATION UNDER USUAL CONDITIONS.

FOLLOW THE LONG TERM STORAGE (MORE THAN 30 DAYS) OR STORAGE AT EXTREME COLD TEMPERATURES (25°F TO -25°F) WINTERIZATIONS PROCEDURE INSTRUCTIONS IN WP 67 IN TM 3-4230-238-23&P.

IF THE M12A1 IS GOING TO BE STORED LESS THAN 24 HOURS, FOLLOW STEP 1. FOR 24-48 HOURS, FOLLOW STEP 2. FOR MORE THAN 48 HOURS, FOLLOW STEP 3.

# CAPS, PLUGS, BAGS? WE'VE GOT YOU COVERED!

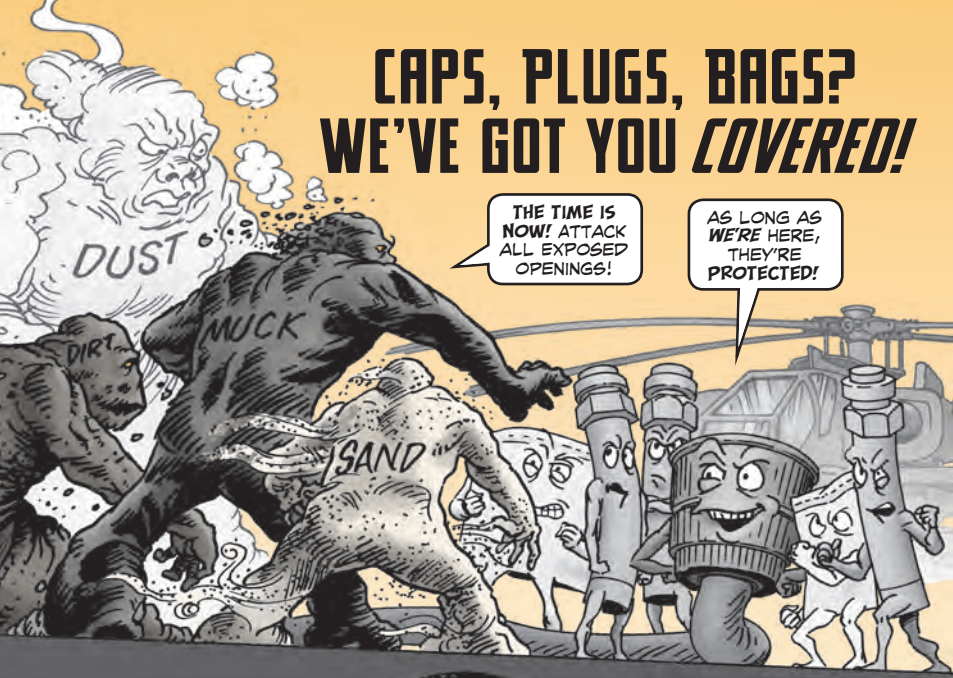

LEAVING HOSES, LINES, TUBES, FITTINGS AND CONNECTORS UNCOVERED IS A DEFINITE MAINTENANCE NO-NO. WHY?

I'LL TELL YOU WHY!



- Moisture dilutes lubes and causes corrosion and engine wear.
- Dirt gets into holes and open lines, contaminating fluids and preventing connectors from sealing.
- Sand and pebbles plug connectors, damaging delicate pins.

## SO WHAT'S THE SOLUTION?

ANY TIME YOU DISCONNECT HOSES, LINES, TUBES, FITTINGS AND CONNECTORS, COVER 'EM. IF YOUR EQUIPMENT'S TM CALLS OUT A SPECIFIC CAP OR PLUG, USE IT.

BUT IF NOT, ORDER FROM THE FOLLOWING SELECTION OF CAPS, PLUGS AND BAGS. NSN 5340-00-450-5718 GETS 121 PROTECTIVE CAPS IN VARIOUS SIZES FOR LESS THAN \$16. THAT'S A GREAT DEAL!

OR YOU CAN ORDER THESE SPECIFIC CAP SIZES:

Diameter (inches)	Length (inches)	NSN 5340-
5/16	7/8	00-777-4620
3/8	3/4	01-170-6662
1/2	3/4	01-187-8957
11/16	3/4	00-930-0839
3/4	3/4	01-044-2675
13/16	7/8	00-993-4185
7/8	2 1/2	00-491-7583

FOR TUBE PLUGS, USE THESE NSNS...



Hydraulic Tube Cap (flareless), NSN 4730-	Outside Diameter (inches)
00-837-9842	1/8
00-115-0210	3/16
00-985-5165	5/16

Cap Tube (Flared), NSN 4730-	Outside Diameter (inches)
00-221-2126	3/16
01-061-4150	5/16
00-585-8769	3/8
00-221-2127	5/8
01-359-4271	3/4
00-221-2129	1

Tube Plug (flared), NSN 4730-	Outside Diameter (inches)
00-287-0109	1/8
00-287-0100 (plain)	3/16
00-287-0110	1/4
00-287-0112	3/8
00-287-0113	1/2
00-287-0116	3/8
00-080-3091	3/4
00-287-0118	1

Hydraulic Tube Plug (flareless), NSN 4730-	Outside Diameter (inches)
00-540-2231	1/8
00-595-3917	3/16

IF YOU HAVE NO CAPS OR PLUGS, USE PLASTIC BAGS TO COVER ALL EXPOSED OPENINGS AND DISCONNECTED LINES.

BAGS ARE ALSO GOOD FOR HOLDING NUTS, BOLTS AND OTHER PARTS THAT ARE REMOVED DURING MAINTENANCE.

HERE ARE A FEW BAG SIZES:

Size (inches)	NSN 8105-
8x6	00-137-9133
10x8	00-137-9134
12x12	00-837-7757

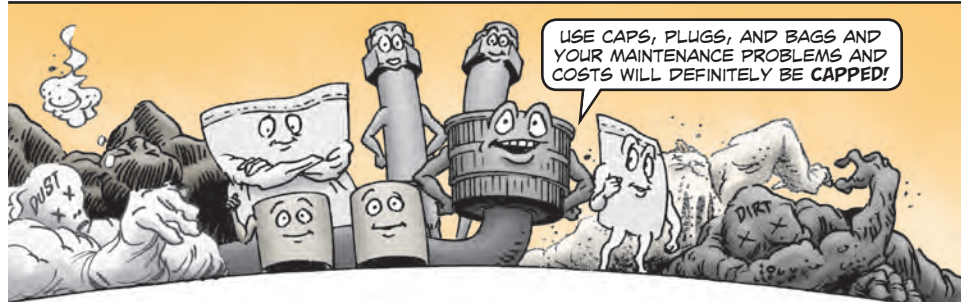
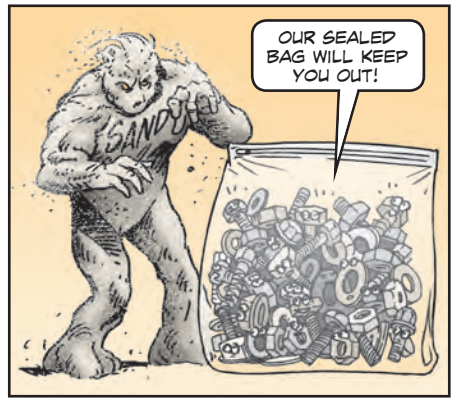



# GAS PROBLEMS? TRY THESE INDUSTRIAL SOLUTIONS!

IF YOU NEED INDUSTRIAL GAS, THEN YOU NEED TO CHECK OUT DEFENSE LOGISTICS AGENCY-AVIATION (DLA-AVIATION).

THEIR GAS PROGRAM PROVIDES INDUSTRIAL GASES, CYLINDERS AND CYLINDER PARTS.

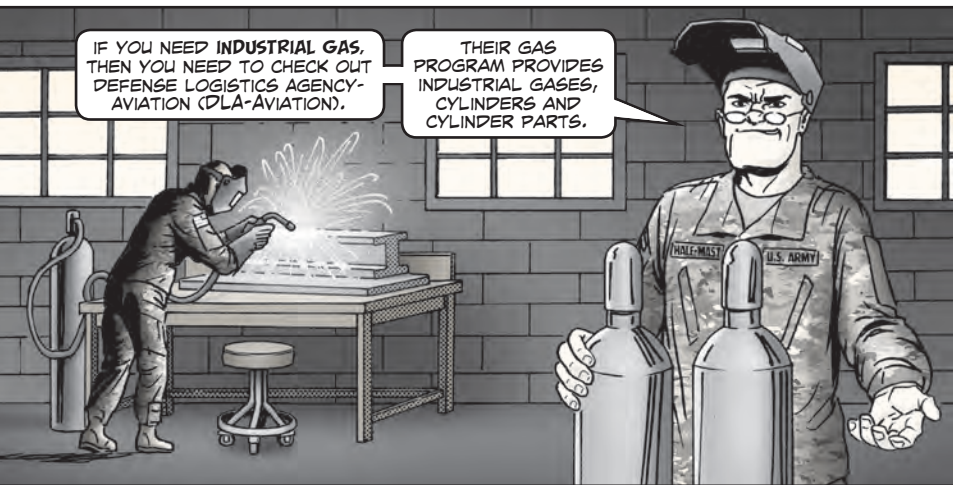

HERE'S WHAT THE PROGRAM CAN DO FOR YOU...

- Supply compressed and liquefied gases in a variety of cylinder sizes.
- Deliver full cylinders to your unit. Products usually ship in one to three days depending on priority after your order is received.
- Charge for the gas only. No extra charge for returnable, reusable cylinders.
- Pick up empty, reusable cylinders from your CONUS site (in most cases).
- Recertify and refurbish cylinders. Customer unit prices include this service.
- Forecast your gas need and maintain a ready-to-ship inventory based on your demand history.
- Provide safety data sheets (SDS) through the Hazardous Materials Information Resource System (HMIRS).
- Manage wholesale inventory.

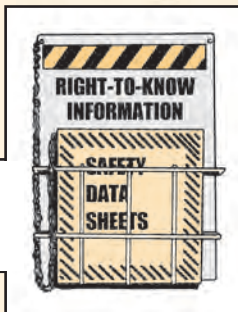

## How to Order

FOR A COMPLETE LIST OF GAS AND CYLINDER NSNs FOR AVIATION AND FOR GROUND APPLICATIONS, GO TO THE GAS WEB PAGE:

<http://www.dla.mil/Aviation/Offers/Products/Commodities.aspx>

LOOK UNDER CONUS INDUSTRIAL GASES AND CYLINDERS PRIVATIZATION PROGRAM. THERE YOU'LL FIND LINKS TO GAS AND CYLINDER NSNs, PROGRAM FACTS AND INFO ON THE RETURN OF EMPTY CYLINDERS.

## GASES & CYLINDERS PROGRAMS:

CONUS Industrial Gases and Cylinders Privatization Program:

Fact Sheet | Brochure | CONUS/CONUS Gas Program NSNs  
Cylinder Returns Fact Sheet

ACETYLENE, ARGON, CARBON DIOXIDE, HELIUM AND REFRIGERANTS ARE JUST SOME OF THE GASES AVAILABLE FROM THE PROGRAM.

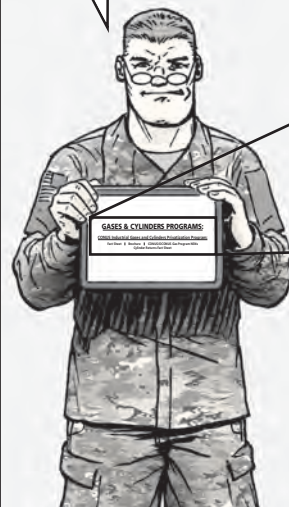

## Cylinder Returns

TO ARRANGE INDUSTRIAL GAS CYLINDER RETURNS TO HUDSON TECH, EMAIL: [cylreturns@hudsontech.com](mailto:cylreturns@hudsontech.com)

WHEN REQUESTING TURN-IN ASSISTANCE, PROVIDE THE FOLLOWING INFORMATION:

- Customer POC information (DODAAC/phone number/email address)
- Cylinder NSN
- Gas type
- Quantity
- Ship From location

YOU'LL RECEIVE EITHER AN EMAIL OR A PHONE CALL WITH PICK-UP INFORMATION OR SHIPPING INSTRUCTIONS FOR THE CYLINDERS.

YOUR LOCATION DETERMINES WHETHER HUDSON TECH PICKS THEM UP OR YOU SHIP THEM.

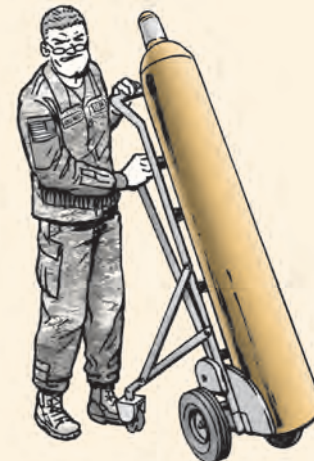

# THE WORD on Vehicle Support Stands



PAGE 43 IN PS 764 (JULY 16) TOLD YOU TO GET JACK STANDS LOAD TESTED EVERY SIX MONTHS FOLLOWING TB 43-0142, SAFETY INSPECTION AND TESTING OF LIFTING DEVICES.

AS SEVERAL READERS POINTED OUT, THAT'S **WRONG**. JACK STANDS, OR MORE ACCURATELY, VEHICLE SUPPORT STANDS, **DON'T EVER NEED TO BE LOAD TESTED.**

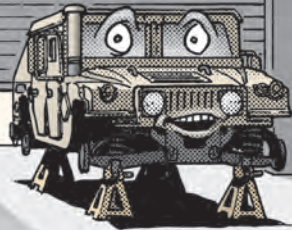

VEHICLE SUPPORT STANDS **DO NOT** REQUIRE FUNCTIONAL TESTS AS TB 43-0156, SAFETY INSPECTION AND OPERATION OF STAND, VEHICLE SUPPORT, STATES. PERIODIC LOAD TESTING OF JACK STANDS DOES MORE HARM THAN GOOD. IF THE STAND'S BEEN TESTED OR CERTIFIED BY THE MANUFACTURER, THAT'S THE **ONLY** TESTING IT WILL EVER NEED.

**HERE ARE MORE ANSWERS TO COMMON JACK STAND QUESTIONS...**



IS LOAD TESTING REQUIRED AFTER REPAIRING JACK STANDS?

NO, BECAUSE JACK STANDS **SHOULDN'T** BE REPAIRED. THE TB STATES "NO ALTERATIONS SHALL BE MADE OR ATTACHMENTS ADDED TO THIS PRODUCT."



IF A JACK STAND FAILS INSPECTION, FOLLOW THE INSTRUCTIONS IN PARA 8P(3) OF TB 43-0156, WHICH SAYS TO DISABLE THE STAND, SEGREGATE IT FROM GOOD STANDS AND DISPOSE OF IT AS SOON AS POSSIBLE.

WHAT REPLACES THE FUNCTIONAL LOAD TEST REQUIREMENTS OF TB 43-0142, SAFETY INSPECTION AND TESTING OF LIFTING DEVICES?

PARA 7B OF TB 43-0156 SAYS...

"LOCAL PURCHASERS OF COMMERCIAL STANDS SHALL REQUIRE SUPPLIERS OF THE STANDS TO PROVIDE PROOF OF A QUALIFIED LOAD TEST EITHER FROM THE MANUFACTURER OR A TESTING FACILITY. THE CERTIFICATE OF CONFORMANCE (COC) WITH THE LOAD TESTING CERTIFICATION REQUIRED FOR LOCALLY PURCHASED STANDS WILL BE MAINTAINED BY THE UNIT."



TB 43-0142 IS STILL WHAT TO FOLLOW FOR LIFTING DEVICES.

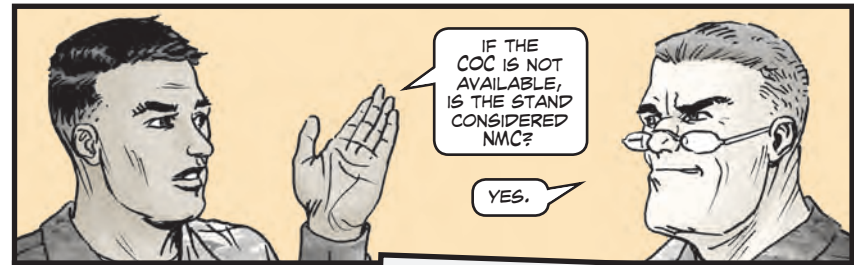

IF THE COC IS NOT AVAILABLE, IS THE STAND CONSIDERED NMC?

YES.

CAN UNITS PRODUCE THEIR OWN COC IF THEY DON'T HAVE ONE?

YES. TACOM MAINTENANCE ADVISORY MESSAGE (MAM) 05-035 SAYS...



"LOCALLY PURCHASED VEHICLE SUPPORT STANDS MUST BE TESTED PRIOR TO PLACING THEM INTO SERVICE. THE LOCAL PURCHASE ORDER (PO) CONTRACT SHOULD SPECIFY PROOF OF LOAD TESTING REQUIREMENTS.

A CERTIFICATE OF TEST RESULTS FOR EACH VEHICLE SUPPORT STAND DELIVERED FROM THE MANUFACTURER OR SELLER WILL BE ACCEPTABLE FOR THIS PURPOSE AND IF ACCEPTED MUST BE KEPT ON FILE.

IF NO SUCH CERTIFICATE IS DELIVERED WITH THE VEHICLE SUPPORT STANDS, THEN THE USING UNIT IS REQUIRED TO VERIFY THE PROOF LOAD CAPABILITY OF EACH VEHICLE SUPPORT STAND, CREATE A CERTIFICATE TO RECORD COMPLIANCE OF EACH INDIVIDUAL VEHICLE SUPPORT STAND AND KEEP THE CERTIFICATE ON FILE."

IS A COC REQUIRED FOR STANDS PURCHASED THROUGH THE ARMY SUPPLY SYSTEM?



NO. PARA 7A OF TB 43-0156 SAYS "IF A VEHICLE SUPPORT STAND HAS A US ARMY DATA PLATE AFFIXED WITH A CONTRACT NUMBER STAMPED ON THE DATA PLATE, THE STAND HAS BEEN TESTED AND A COC IS NOT REQUIRED."



IS A JACK STAND NMC WITHOUT THE PRODUCT MARKINGS REQUIRED BY APPENDIX B OF TB 43-0156?

YES. WITHOUT PRODUCT MARKINGS, IT'S VERY HARD TO TRACE THE EQUIPMENT BACK TO ITS COC. CONSIDER CONTACTING THE MANUFACTURER OR SUPPLIER FOR THESE MISSING MARKINGS, PLATES OR LABELS.



**PS MORE**

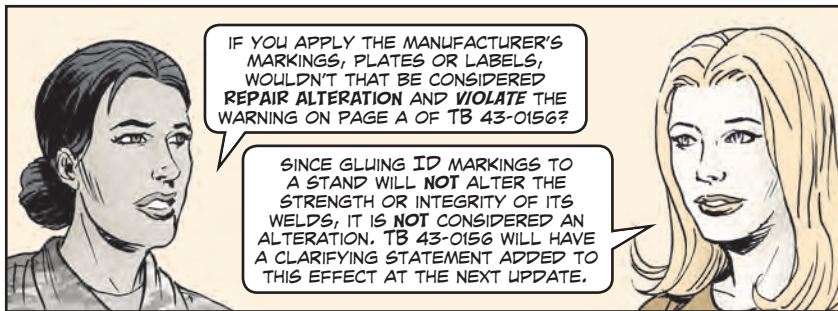

IF YOU APPLY THE MANUFACTURER'S MARKINGS, PLATES OR LABELS, WOULDN'T THAT BE CONSIDERED REPAIR ALTERATION AND VIOLATE THE WARNING ON PAGE A OF TB 43-0156?

SINCE GLUING ID MARKINGS TO A STAND WILL NOT ALTER THE STRENGTH OR INTEGRITY OF ITS WELDS, IT IS NOT CONSIDERED AN ALTERATION. TB 43-0156 WILL HAVE A CLARIFYING STATEMENT ADDED TO THIS EFFECT AT THE NEXT UPDATE.



DOES THE ARMY HAVE NSNs FOR ORDERING THESE MARKINGS?

NO. YOU MIGHT WANT TO CONSIDER MAKING YOUR OWN AND GLUING IT TO THE STAND YOURSELF.

APPENDIX B OF TB 43-0156 GIVES AN EXAMPLE OF THE INFORMATION NEEDED FOR PRODUCT MARKINGS. THERE IS ALSO A SAFETY MARKING EXAMPLE THAT CAN BE COPIED AND GLUED TO THE STAND IF NEEDED.

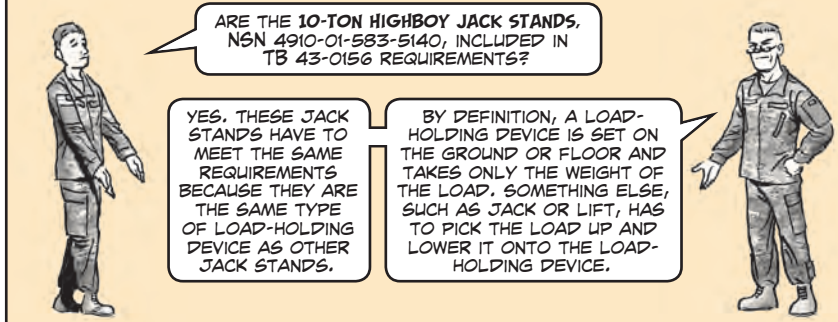

ARE THE 10-TON HIGHBOY JACK STANDS, NSN 4910-01-583-5140, INCLUDED IN TB 43-0156 REQUIREMENTS?

YES. THESE JACK STANDS HAVE TO MEET THE SAME REQUIREMENTS BECAUSE THEY ARE THE SAME TYPE OF LOAD-HOLDING DEVICE AS OTHER JACK STANDS.

BY DEFINITION, A LOAD-HOLDING DEVICE IS SET ON THE GROUND OR FLOOR AND TAKES ONLY THE WEIGHT OF THE LOAD. SOMETHING ELSE, SUCH AS JACK OR LIFT, HAS TO PICK THE LOAD UP AND LOWER IT ONTO THE LOAD-HOLDING DEVICE.

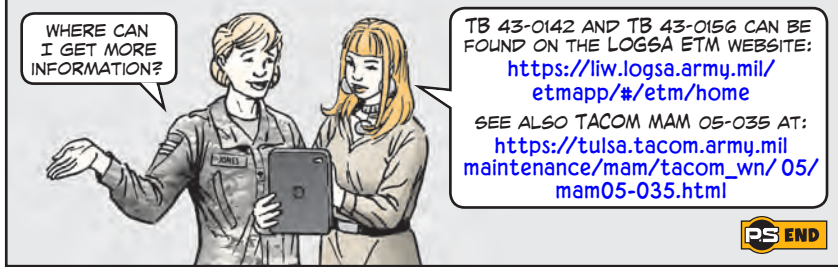

WHERE CAN I GET MORE INFORMATION?

TB 43-0142 AND TB 43-0156 CAN BE FOUND ON THE LOGSA ETM WEBSITE:  
<https://liw.logsa.army.mil/etmapp/#/etm/home>  
SEE ALSO TACOM MAM 05-035 AT:  
[https://tulsa.tacom.army.mil/maintenance/mam/tacom\\_wn/05/mam05-035.html](https://tulsa.tacom.army.mil/maintenance/mam/tacom_wn/05/mam05-035.html)

PS END

# PS COMMUNICATIONS & SOLDIER SUPPORT

- High Time to Turn in DISE
- 15-kW AMMPS Generator Oil Filter
- DD Form 1380 Provides Critical Info for Emergency Care



Click here for a copy of this article to save or email.

# High Time to Turn in DISE

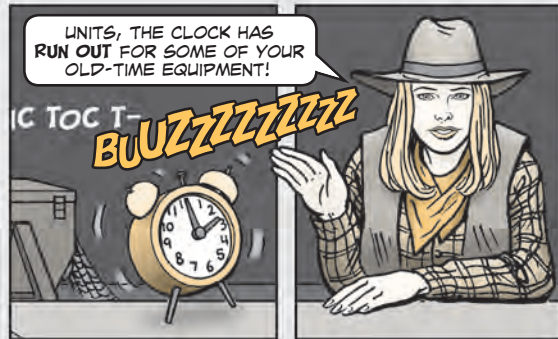

THE MAINTENANCE EXPENDITURE LIMIT (MEL) FOR THE M40, M60, M100 AND M200 DISTRIBUTION ILLUMINATION SYSTEMS, ELECTRICAL (DISE), IS NOW PERMANENTLY ZERO.

CECOM'S LATEST VERSION OF TB 43-0002-32 (MAY 16) REFLECTS THIS CHANGE.

THE OLDER DISE SYSTEMS WITH ZERO MEL INCLUDE:	
Nomenclature	NSN 6150-
M40 DISE, 120/208V, 3PH, 40-amp	01-208-9753
M60 DISE, 120V, 1 PH, 60-amp	01-208-9752
M100 DISE, 3PH, 100-amp	01-208-9754
M200 DISE, 3PH, 200-amp	01-208-9755

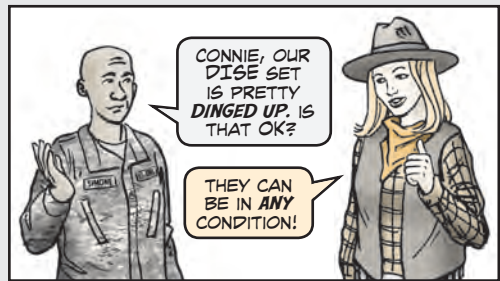
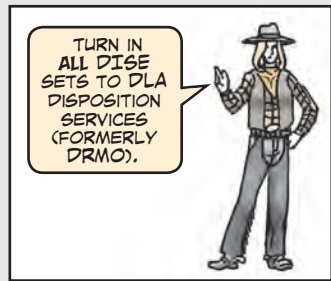

IF YOUR UNIT STILL HAS AUTHORIZED DISE SETS YOU'RE USING IN PLACE OF THE NEWER POWER DISTRIBUTION ILLUMINATION SYSTEMS, ELECTRICAL (PDISE) AUTHORIZED SYSTEMS, YOU MUST FIRST TURN IN THE DISE SETS TO CREATE A SHORTAGE AND THEN SUBMIT A REQUISITION FOR PDISE.

TO FIND THE PDISE EQUIVALENT NSN FOR YOUR OLDER DISE SYSTEM, CHECK THE FOLLOWING TABLE:

DISE		PDISE	
Item	NSN 6150-	Item	NSN 6150-
M40 DISE	01-208-9753	M40 PDISE	01-307-9446
M60 DISE	01-208-9752	M60 PDISE	01-307-9445
M100 DISE	01-208-9754	M100 PDISE	01-308-5671
M200 DISE	01-208-9755	M200 PDISE	01-308-5672

AFTER THE PDISE REQUISITION IS SUBMITTED, EMAIL THE FOLLOWING INFORMATION TO THE COMMUNICATIONS-ELECTRONICS COMMAND (CECOM) LIFE CYCLE MANAGEMENT COMMAND (LCMC) AND PROJECT MANAGER, EXPEDITIONARY ENERGY AND SUSTAINMENT SYSTEMS (PM E2S2):

- Document number
- Unit identification code (UIC)
- PDISE NSN
- Quantity of shortage
- Ship-to DODAAC
- Email address and phone number of the person/property book officer signing for the PDISE receipt.

SEND THIS ABOVE INFO TO:

CECOM LCMC'S JOHN MANSFIELD AT: [john.k.mansfield2.civ@mail.mil](mailto:john.k.mansfield2.civ@mail.mil)

AND PM-E2S2'S ISRAEL SANCHEZ AT: [israel.sanchez4.ctr@mail.mil](mailto:israel.sanchez4.ctr@mail.mil)

SENDING INFORMATION TO BOTH PLACES WILL EXPEDITE DELIVERY OF THE REPLACEMENT PDISE.

QUESTIONS? CONTACT JOHN MANSFIELD AT (410) 220-5576, OR USE THE ABOVE EMAIL.

## 15-kW AMMPS Generator Oil Filter

Order a new oil filter for the MEP-1050 15-kW AMMPS generator with NSN 2940-01-589-6600 (PN 119005-35170). NSN 4720-01-546-8857 (PN 119005-35160) was incorrectly listed for Item 15 in Fig 26 of TM 9-6115-751-24&P (Nov 15). That NSN brings a nonmetallic hose. Make a note until the next TM update.

# DD Form 1380 Provides Critical Info For Emergency Care

**T**O ENSURE MILITARY PERSONNEL RECEIVE THE BEST POSSIBLE CARE, DOD MANDATES ANYONE PROVIDING EMERGENCY AID IN THE FIELD MUST FILL OUT A DD FORM 1380, TACTICAL COMBAT CASUALTY CARE (TCCC) CARD.

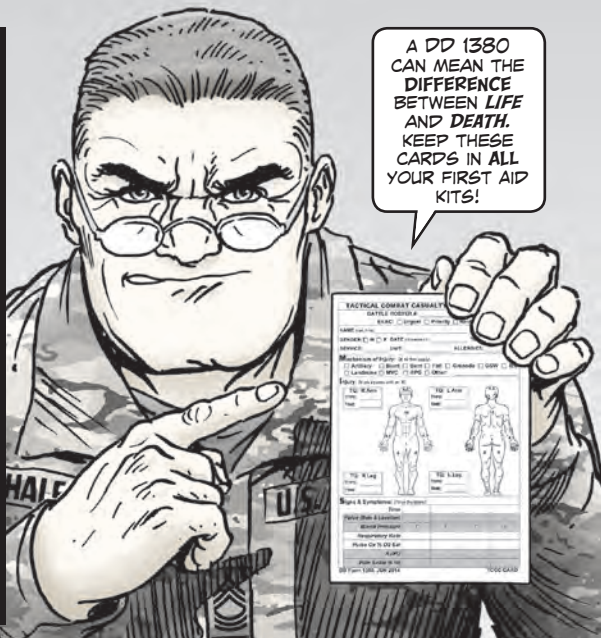

THE TCCC CARD DOCUMENTS PRE-HOSPITAL CARE, INCLUDING ASSESSMENT INFORMATION, INTERVENTIONS, AND MEDICATION. THIS INFORMATION IS CRITICAL TO MEDICAL PROVIDERS' TREATMENT AND IS USED TO UPDATE CLINICAL PRACTICE GUIDELINES, TECHNIQUES AND PROCEDURES.

AFTER THE TCCC CARD IS COMPLETE, ATTACH IT TO THE PATIENT SO THAT IT'S CLEARLY VISIBLE. KEEP PLENTY OF TCCC CARDS IN ALL COMBAT LIFESAVER BAGS, FIRST AID KITS, AND INDIVIDUAL/JOINT FIRST AID KITS (IFAK/JFAK).

INSTRUCTIONS FOR FILLING OUT THE TCCC CARD ARE IN TABLES 1 AND 2 IN ENCLOSURE 4 OF DHA-PI 6040-01:

<https://health.mil/About-MHS/Defense-Health-Agency/Resources-and-Management/DHA-Publications>

PRINT OUT THE INSTRUCTIONS AND CLIP THEM TO THE TCCC CARDS.

ORDER NEW CARDS FROM DLA DOCUMENT SERVICES:

<https://navalforms.documentservices.dla.mil/web/public/home>

CLICK ON FORMS AND THEN CLICK ON KEYWORD SEARCH.

TYPE IN DD 1380 AND CLICK ON SEARCH. THE CARDS WILL BE LISTED IN TWO QUANTITIES: **10** OR **100**. CLICK ON THE NUMBER YOU NEED.

A DEFENSE AUTOMATED PRINTING SERVICES (DAPS) ACCOUNT IS NEEDED TO ORDER CARDS THROUGH DLA. IF YOU DON'T HAVE AN ACCOUNT, SEE THE CUSTOMER ASSISTANCE HANDBOOK FOR INSTRUCTIONS ON HOW TO ESTABLISH AN ACCOUNT:

<https://forms.documentservices.dla.mil/public/Naval%20Forms%20Online%20website%20instructions.pdf>

OR YOU CAN ORDER 100 TCCC CARDS WITH NSN 7540-01-647-6165 OR 10 WITH NSN 7540-01-651-8602.

# PS LOGISTICS

- Introducing the Mighty, Magnificent HMIRS Next Gen
- Don't Toss 'Em!
- TM Shortages Short Readiness
- DLA Helps with Office Devices

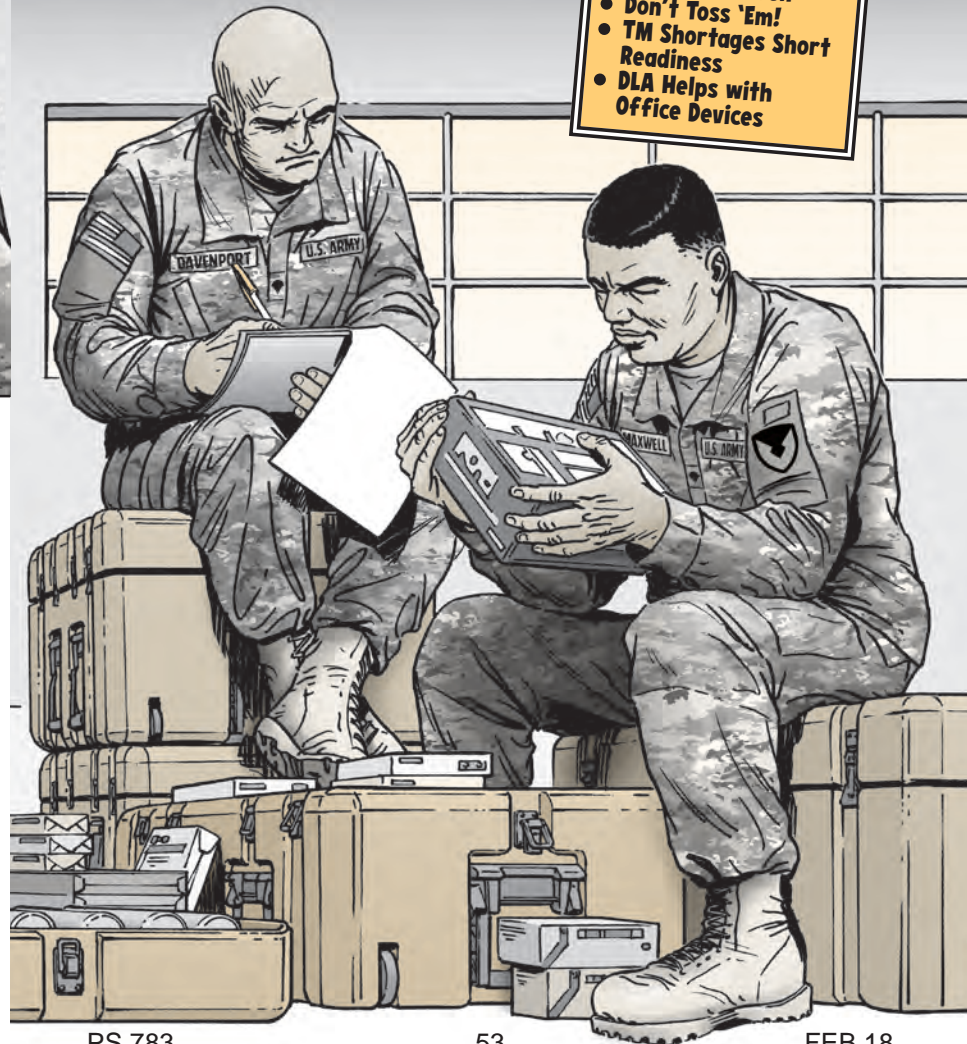

# Introducing the Mighty, Magnificent ~~HMIRS~~ ~~HMMS~~

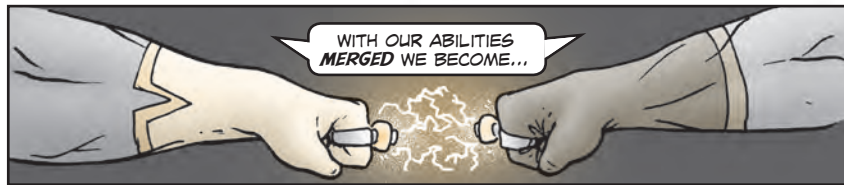
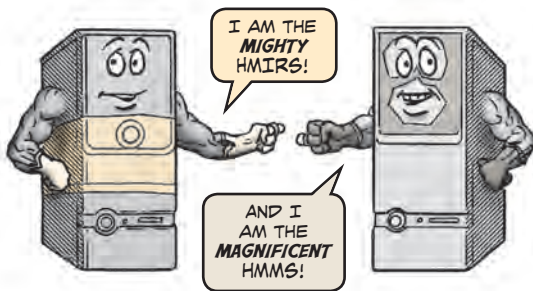

CUSTOMERS WITH AN ACCOUNT MANAGEMENT AND PROVISIONING SYSTEM (AMPS) PROFILE WILL AUTOMATICALLY BE MOVED TO THE NEW SYSTEM, BUT YOU'LL STILL NEED TO REGISTER YOUR ROLE IN AMPS.

NEW CUSTOMERS WILL NEED TO REQUEST AN AMPS ACCOUNT AND REGISTER THEIR ROLE. GET ACCESS TO AMPS AT:  
<https://amps.dla.mil>

ONCE THE AMPS ACCOUNT IS SET UP, USERS RECEIVE AN EMAIL WITH A LINK TO THE WEBSITE AND A PASSWORD. CAC-AUTHORIZED USERS CAN ALSO GO TO:  
[https://h2.hmms.hill.af.mil/HMMS\\_Web\\_JSF/login.xhtml](https://h2.hmms.hill.af.mil/HMMS_Web_JSF/login.xhtml)

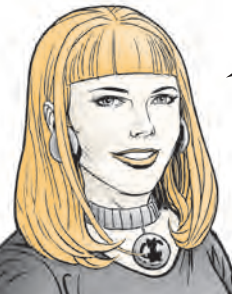
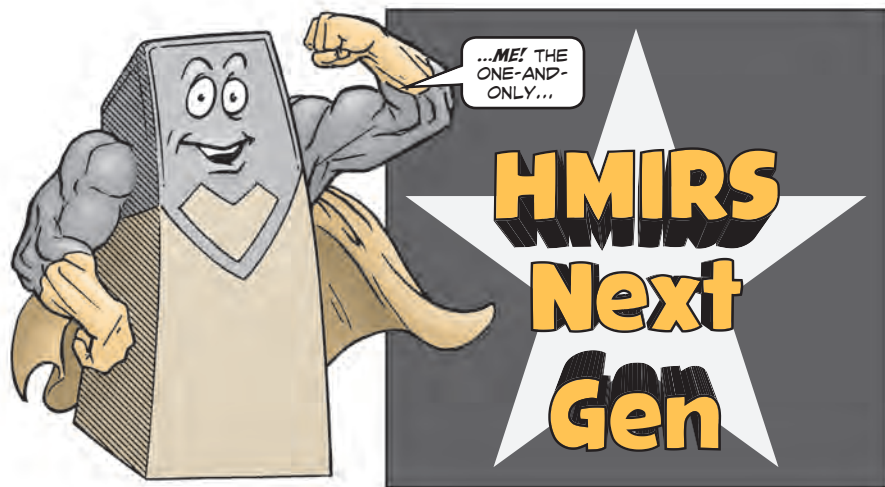
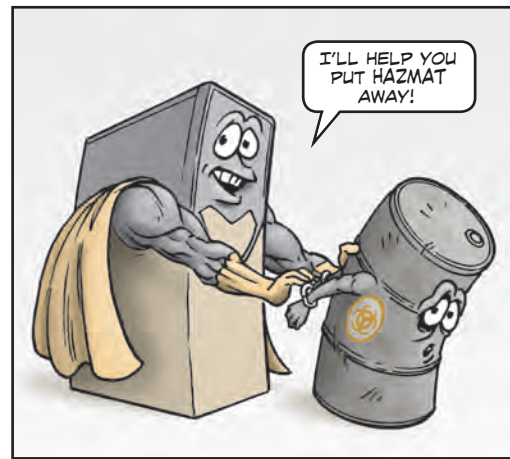

IF YOU'RE LOOKING FOR INFORMATION ON HAZARDOUS MATERIAL (HAZMAT), TRY THE **NEW AND IMPROVED** HAZARDOUS MATERIAL INFORMATION RESOURCE SYSTEM, NEXT GENERATION (HMIRS NEXT GEN).

THE DEPARTMENT OF DEFENSE'S (DOD) HMIRS SYSTEM MERGED WITH THE DEFENSE LOGISTICS AGENCY'S (DLA) HAZARDOUS MATERIAL MANAGEMENT SYSTEM (HMMS) TO OFFER:

- enhanced navigation capabilities
  - better filtering to quickly find information
  - reduced data entry times
- FOR THE **20,000 PLUS DOCUMENTS** ADDED TO THE SYSTEM **EACH YEAR.**

DA Form 348...

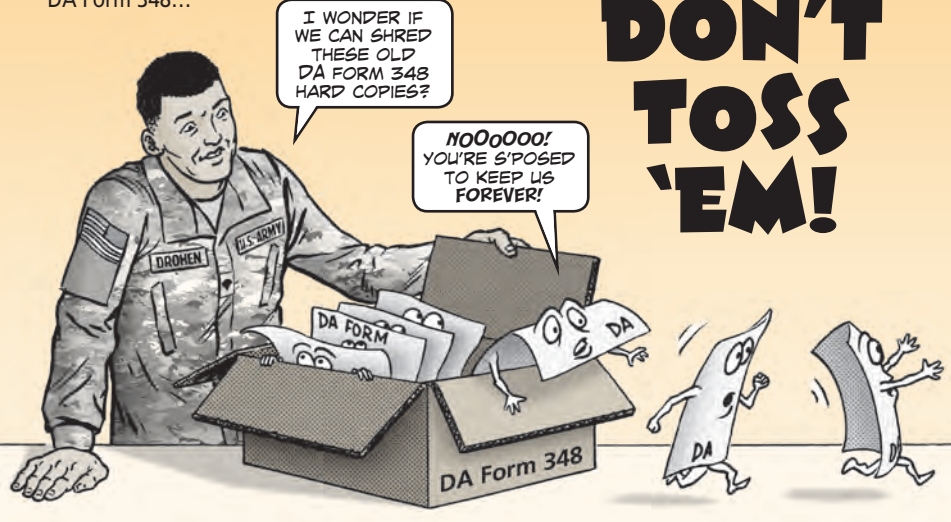

**G**ot a box of old DA Form 348s sitting around the office? **Don't throw those away!** The DA Form 348, *Equipment Operator's Qualification Record*, contains information that never gets transferred to the electronic system.

Soldiers get an updated DA Form 348 as a part of out-processing for PCS, ETS or retirement. The DA Form 348 is the official, permanent document of record and should **NOT** be destroyed.

# TM SHORTAGES SHORT READINESS

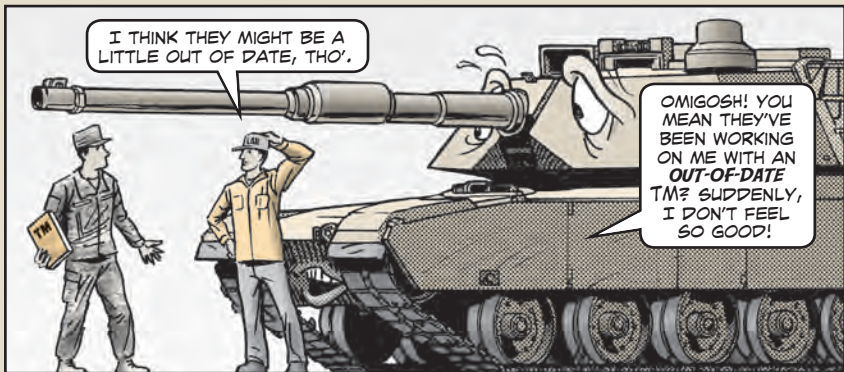
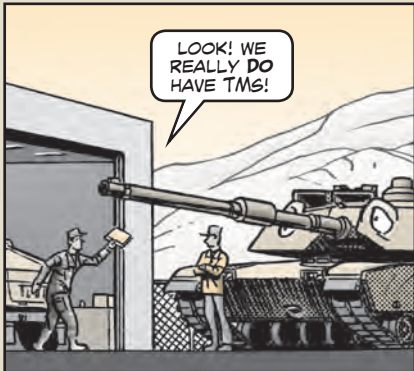

Dear Editor,

During our COMET unit inspections, we often find shortages of TMs for both the operators and unit repairmen. And the units seem unsure what to do about it.

Of course, lack of TMs can lead to disaster for both Soldiers and the equipment. Without TMs, Soldiers don't have publications to refer to for correct operations, PMCS, troubleshooting, maintenance procedures, and repair parts.

First of all, units need to realize that TMs are free—the Army pays for them, not the individual units. They are not saving money by not ordering TMs. No TMs will cost them money sooner or later, maybe lots of money in repairs.

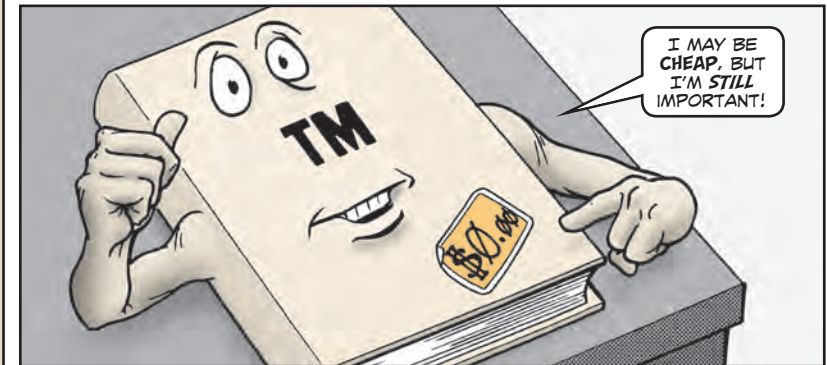

Units don't need to be puzzled about who to turn to for ordering TMs. Every battalion has a pubs account that is usually managed by the Personnel Administrative Center, commonly known as the S-1 shop. The S-1 should have a pubs clerk who can order TMs from the Army Publishing Directorate (APD).

Once a TM subscription is established, units will not only get the TMs, but also will automatically receive updates to the TMs.



That brings up another point: Units must post changes to the TMs. We often find units using outdated TMs, which means they may be missing critical information.

Of course, all this trouble is for nothing if the TMs never make it out of brigade. They must go to the operators and repairmen who need them. Units should follow up to see if their TMs have arrived.



WHERE AM I GONNA PUT THIS STACK OF TMS?

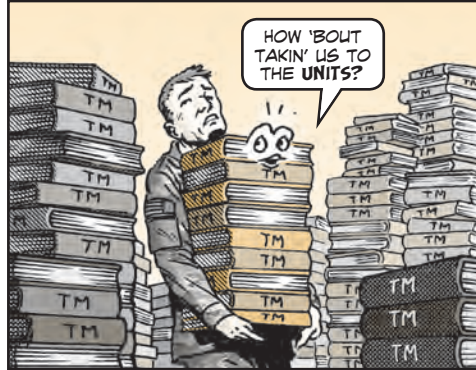

We also run into units going to the field without TMs. Units should ensure they have every TM they will need with no exceptions.

Units can get a publications tailored index list (PTIL) of what TMs they need by one of two methods:

- Email their unit identification code (UIC) to the Logistics Support Activity (LOGSA): [usarmy.redstone.logsa.mbx.eopdb@mail.mil](mailto:usarmy.redstone.logsa.mbx.eopdb@mail.mil) or call DSN 645-8586, (256) 955-8586.
- Download TMs from LOGSA's ETM website at: <https://liw.logsa.army.mil/etmapp/#/etm/home>

This is the Army's official website for IETMs and TMs and is available 24/7.

Ricky Sanders  
COMET



WE ALSO RUN INTO THIS PROBLEM WHEN WE GO TO THE FIELD. EVERY UNIT SHOULD ENSURE THEY HAVE EVERY TM THEY NEED—NO EXCEPTIONS.

**DON'T FORGET THE NEW PS MOBILE APP!**

DOWNLOAD IT FREE AT:

ANDROID

<https://play.google.com/store/apps/details?id=mil.logsa.army.psmag&hl=en>

APPLE

<https://itunes.apple.com/us/app/p.s.magazine/id1082232259?mt=8>



# DLA Helps with Office Devices

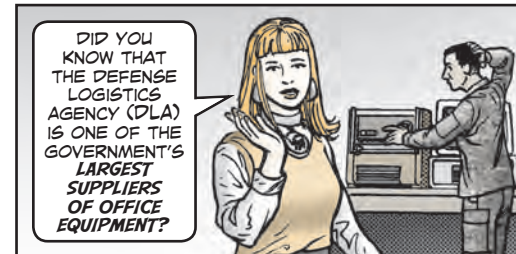
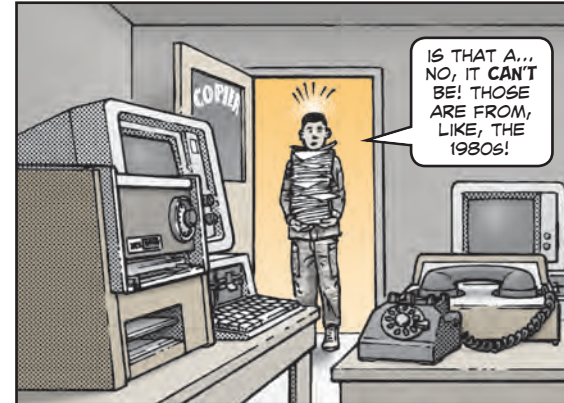
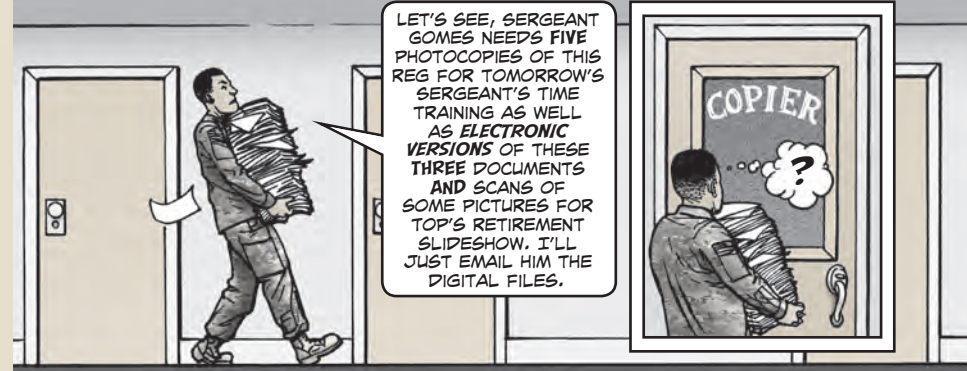

THE DLA EQUIPMENT MANAGEMENT SOLUTIONS PROGRAM (EMS) CAN HELP YOUR ORGANIZATION REPLACE OLD, SINGLE-FUNCTION EQUIPMENT WITH NEWER NETWORKED MULTIFUNCTIONAL DEVICES (MFD).  
DLA ALSO PROVIDES SUPPORT FOR THE NEW GEAR, INCLUDING INSTALLATION, TRAINING AND CUSTOMER SUPPORT.

**FIND OUT MORE ABOUT THE EMS PROGRAM HERE:**

<http://www.dla.mil/HQ/InformationOperations/DocumentServices/Offers/OfficeDeviceManagement.aspx>



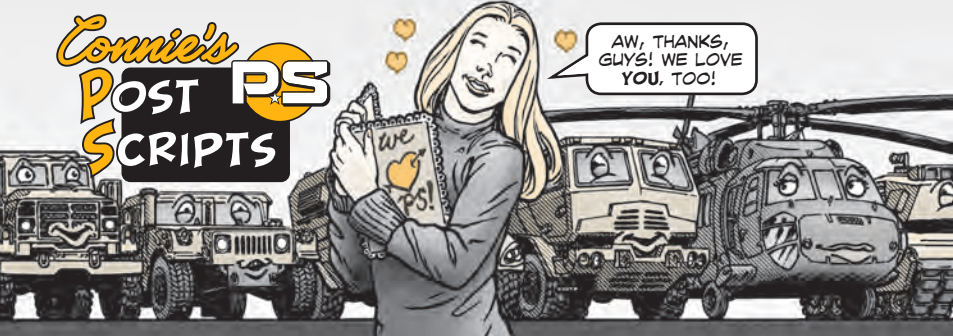

### PLS E-CHU Hydraulic Manifold

Order a new PLS E-CHU hydraulic manifold with NSN 4730-20-009-4458 (PN 111574801, CAGE 3AR59). The manifold shown as Item 20 in Fig 1 of TM 9-3950-253-13&P (Feb 15) has an SMR code of XDFZZ and can't be ordered by NSN. Note that the SMR code for the new manifold is PAFZZ. Make a note until the TM is updated.

### PLS E-CHU Roller Beam Parts

Two of the PLS E-CHU roller beam parts listed in Fig 12 of TM 9-3950-253-13&P (Feb 15) have been replaced. The nut listed as Item 18 doesn't lock and has the potential to vibrate loose. Replace it with a locking hexagon nut, NSN 5340-01-542-6331 (PN 97135A270). The cap screw listed as Item 19 is too long. Replace it with hexagon cap screw, NSN 5306-01-560-2706 (PN 92620A804).

### AN/TSC-183A SATCOM PN Correction

In Item 16 on Page 47 in PS 780 (Nov 17), the telephone set (7811G phone bundle), has the wrong part number. Change PN 02-2856212-1 to PN CP-7811-K9. The NSN is correct.

### M915A5

#### VORAD Side Sensor

Get the M915A5 tractor truck's VORAD side sensor with NSN 6350-01-576-6616 (PN 06-66082-000, CAGE 64678). It replaces PN K070289 (CAGE 06853), which is shown as Item 18 in Fig 279 of TM 9-2320-426-13&P in IETM EM 0308 (Aug 14).

#### Taillight NSN

Get a new taillight for your M915A5 tractor truck with NSN 6220-01-544-5789. NSN 6220-01-550-1399, which is shown as Item 1 in Fig 103 of TM 9-2320-426-13&P in IETM 0308 (Aug 14), brings the wrong light. Make a note until the TM is updated.

#### Windshields

Need a new windshield for your M915A5? NSN 2510-01-617-8631 brings the right-hand windshield and NSN 9340-01-578-6446 the left-hand windshield. Make a note until TM 9-2320-426-13&P in IETM EM 0308 (Aug 14) is updated.

#### Front Speed Sensor NSN

Get a new front speed (straight) sensor for your M915A5 with NSN 2530-01-585-2067. It replaces NSN 2530-01-534-6272, which is shown as Item 1 in Fig 80 of TM 9-2320-426-13&P in IETM EM 0308 (Aug 14). That NSN brings the wrong sensor.

### M1022/A1 Dolly Set Gets Hydraulic Fluid Change

The M1022/A1 dolly set lubrication instructions call for OHA (MIL-PRF-5606) for use in the hydraulic pumps. But this fluid doesn't have the necessary anti-corrosive properties. It's not ideal for Army ground vehicle use. OHT (MIL-PRF-6083) is the approved replacement for use in the M1022.

Order it with these NSNs:

Qty	NSN 9150-
1-pt bottle	00-159-4472
1-qt bottle	00-935-9807
1-gal bottle	00-935-9808
5-gal bottle	00-935-9809
55-gal drum	00-935-9810

### LET'S GO WAY BACK...



Ever wonder how Master Sergeant Half-Mast and the gang looked in the 60's or 70's or what PM advice they were sharing with Soldiers in the 80's and 90's? A few PS Magazine super-fans operate an archive filled with past issues of PS going all the way back to our first issue in 1951! To see the archive and a few extra PS goodies, go to:

<http://psmag.radionerds.com/>

### NEED HARDWARE?

The Defense Logistics Agency's (DLA) Troop Support has various hardware fastener catalogs. Look for the catalog links at the bottom of this page:

<http://www.dla.mil/TroopSupport/IndustrialHardware>

### AR 750-1 Revised

The newly revised Army Regulation 750-1 (3 Aug 17), *Army Material Maintenance Policy*, is now available. To keep up with maintenance of supplies and equipment, get your copy from the Army Publishing Directorate: <http://www.apd.army.mil/ProductMaps/PubForm/AR.aspx>

### Drive Well, Earn Kudos

Did you know...*Soldiers are eligible to receive a Drivers' Badge award if they possess an OF 346 or DA Form 5984-E, issued as prescribed by regulation, and are assigned as a driver or assistant driver of an Army motor vehicle for a minimum of 12 consecutive months, or have driven a minimum of 8,000 miles, without an adverse incident (traffic violation) or accident recorded on the Soldier's DA Form 348.*

—AR 600-55, 4-11 (May 17)

Would You Stake Your Life <sup>right now</sup> on the Condition of Your Equipment?

**DO IT  
BY THE  
BOOK!**

GOING BY THE  
BOOK PROTECTS MY  
ELECTRONICS!

WHY DO  
IT ANY  
OTHER  
WAY?!



Do **ALL** the start-up  
and shutdown steps  
in the **RIGHT** sequence  
like the **TM** says!

[Click here for a copy of this article to save or email.](#)